

CIP

CLEANING
IN PLACE



CIP

ABOUT HEXONIC

Since 1988, we deliver proven and innovative heat exchange solutions in the field of heat exchange, building our position on knowledge, hands-on experience, and the trust of our clients. We have extensive expertise in selecting heat exchangers for Cleaning-in-Place (CIP) systems, where the highest hygienic standards are essential.

Our HAD and JAD series heat exchangers are used in CIP installations around the globe, ensuring reliability, hygiene, and exceptional process efficiency. Thanks to our flexible approach and robust technology, we are the partner of choice for a wide range of industries—from food processing to the pharmaceutical sector.



BENEFITS OF USING HEXONIC HEAT EXCHANGERS IN CIP SYSTEMS



fast and stable heating
of cleaning solutions



resistance to aggressive media,
including acids, alkalis, and disinfectants



compact, hygienic design



manufactured in accordance
with ASME, PED



shorter and more
efficient CIP cycles



reduced energy consumption
and operating costs



THE ROLE OF HEAT EXCHANGERS IN CIP SYSTEMS

Safe closed-loop cleaning (CIP-ready).

Our heat exchangers have a corrugated tube design that creates turbulent flow, which greatly improves the self-cleaning effect and reduces the risk of residue buildup.

Efficient heating of cleaning solutions.

They rapidly heat cleaning solutions —like NaOH or acid solutions—which boosts the effectiveness of the cleaning process.

Controlled cooling after the cleaning cycle.

After the CIP process, the heat exchangers allow the system to cool down gradually, getting it ready for rinsing with water or moving on to the next stage of production.

Consistent process temperature.

They keep the temperature steady during the entire CIP cycle, which is key for consistent results, process control, and meeting hygiene standards.

Longer lifespan, no downtime.

By eliminating elastomers, the system offers a long service life without the need for scheduled maintenance interruptions.

HEXONIC HEAT EXCHANGERS IN CIP CLEANING STATIONS

Hexonic heat exchangers are a key part of mobile, container-based, and tank-mounted CIP stations. They heat cleaning solutions quickly and accurately. Their compact size, great thermal performance, and proven reliability make them a smart choice for modern cleaning systems.

In mobile CIP units, these heat exchangers provide efficient heating while keeping the system light and easy to move. They offer stable temperatures, high energy efficiency, and reliable operation even in tough conditions—making them a great fit for the food, chemical, and pharmaceutical industries.

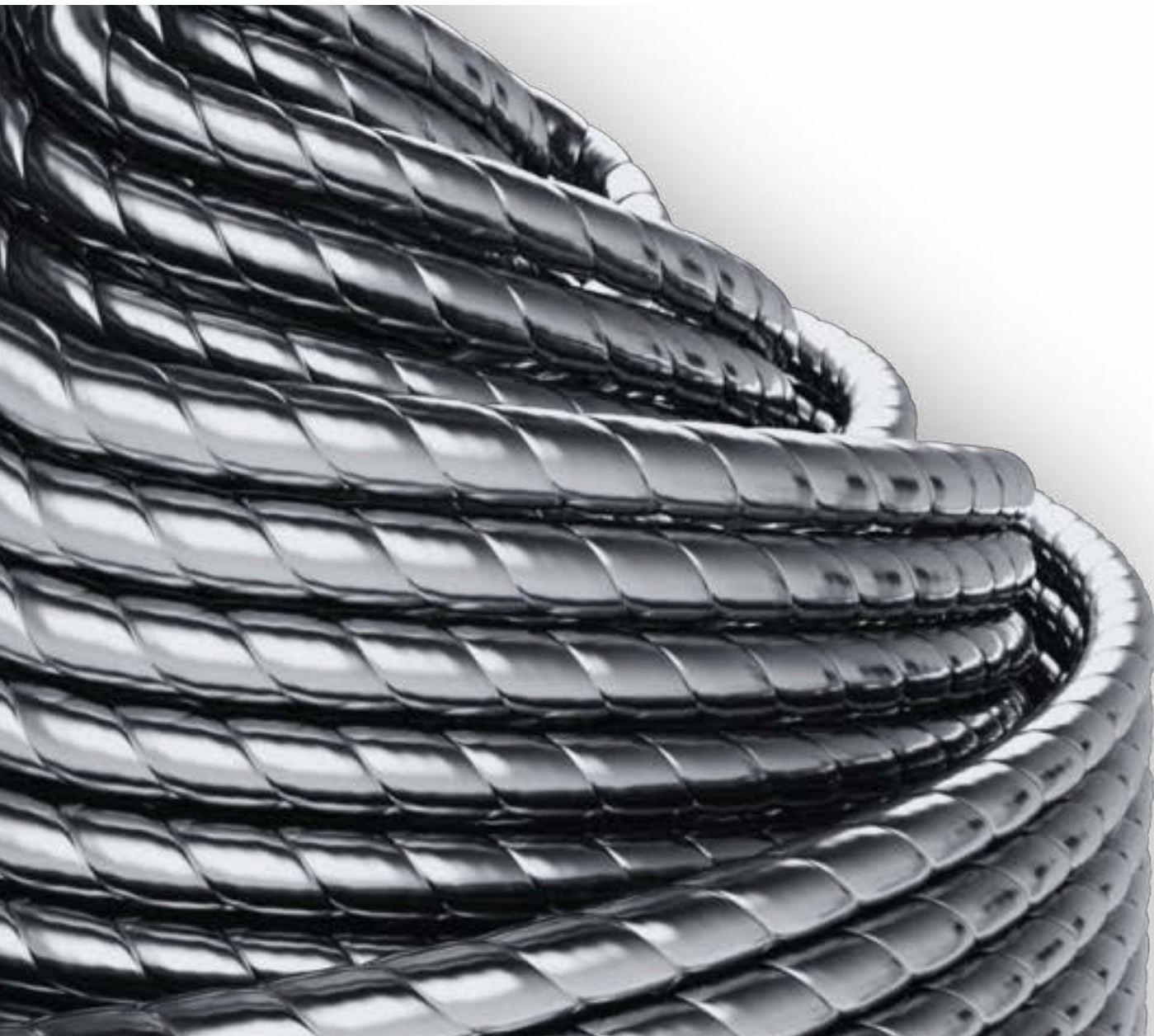

In container-based CIP stations, Hexonic heat exchangers are the heart of the heating system. They provide even heating for alkaline, acidic, and disinfectant solutions. Since they can run two heating circuits at the same time, they support better automation and flexibility—keeping temperatures steady throughout the entire CIP cycle.

In tank-mounted CIP systems, the heat exchangers heat large amounts of cleaning solution across several separate circuits with high accuracy. They deliver strong thermal efficiency, allow precise temperature control in real time, and can serve multiple circuits at once—easily adjusting to user needs while meeting strict hygiene standards.

EXAMPLE OF MEDIUM HEATING IN A CLOSED-LOOP CIRCULATION SYSTEM

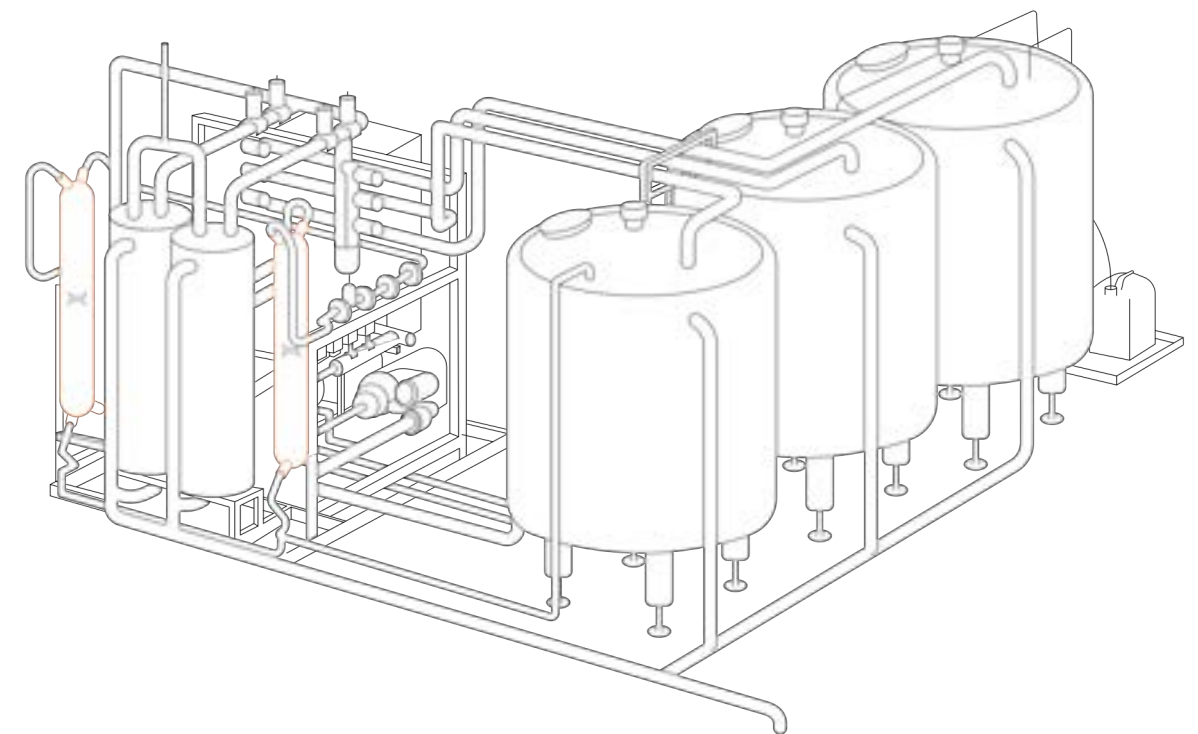

TYPICAL CIP STATION DIAGRAMS IN INDUSTRY

— SINGLE-LINE CIP SYSTEM WITH HAD HEAT EXCHANGER

In the single-line CIP system shown, the HAD heat exchanger is key to heating cleaning solutions—like water, acid, or caustic soda—to the exact temperature needed for effective cleaning of process equipment. It uses steam as the main heat source and transfers heat directly to the cleaning fluid circulating in the CIP loop. Because it works in direct contact with the solution, it responds quickly to changes in heat demand, helping the system run efficiently and reliably.

Advantages of Using HAD | JAD Heat Exchangers in a Single-Line CIP System:

High efficiency

— delivers fast and reliable heating, even when process parameters change dynamically.

Compact design

— easily integrates into confined spaces within CIP installations.

Resistance to aggressive media

— the HAD unit is capable of operating with both acidic and alkaline solutions, making it an ideal choice for demanding cleaning systems.

Ease of maintenance and cleaning

— a critical factor in hygiene-sensitive sectors such as food and pharmaceutical production.

Safety and reliability

— maintains a stable solution temperature throughout the cycle, ensuring repeatability and cleaning effectiveness.

Energy efficiency

— optimized use of steam as a heating medium, with the added benefit of condensate recovery for reduced operational costs.

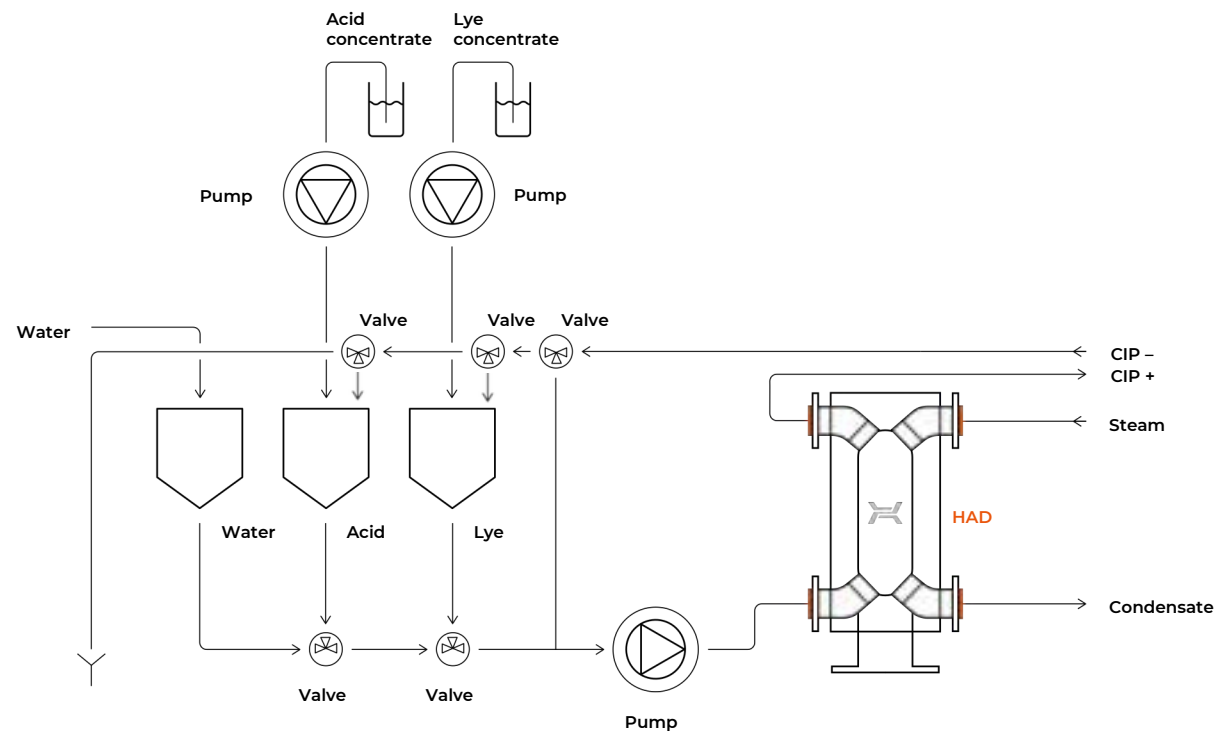

— FOUR-LINE CIP SYSTEM WITH JAD HEAT EXCHANGER

In a four-line CIP installation, each cleaning circuit is equipped with a dedicated JAD heat exchanger responsible for heating the cleaning medium within that loop. These exchangers draw thermal energy from process steam and transfer it to the CIP-side media, ensuring precise and efficient temperature control. This setup allows each circuit to maintain its own temperature, so multiple process lines can be cleaned at the same time—even if they require different heating conditions.

Connected to an advanced automation system with temperature sensors, control valves, and pumps, the exchangers offer accurate and responsive control throughout the entire heating process.

Benefits of using HAD | JAD heat exchangers in a four-line CIP system:

High performance

— each exchanger independently supports intensive heating cycles, even under demanding conditions.

Precision

— individual temperature control in every circuit ensures optimal cleaning efficiency and process safety.

Compatibility with various cleaning agents

— JAD's durable construction is resistant to acids, alkalis, and disinfectants, making it ideal for aggressive cleaning protocols.

Compact and hygienic design

— engineered to meet the strict sanitary standards of the food, chemical, and pharmaceutical industries.

Integrated condensate drainage system

— enhances the energy efficiency of the entire setup by optimizing steam usage and recovery.

The diagram is presented on the following page.



— FOUR-LINE CIP SYSTEM WITH JAD HEAT EXCHANGER

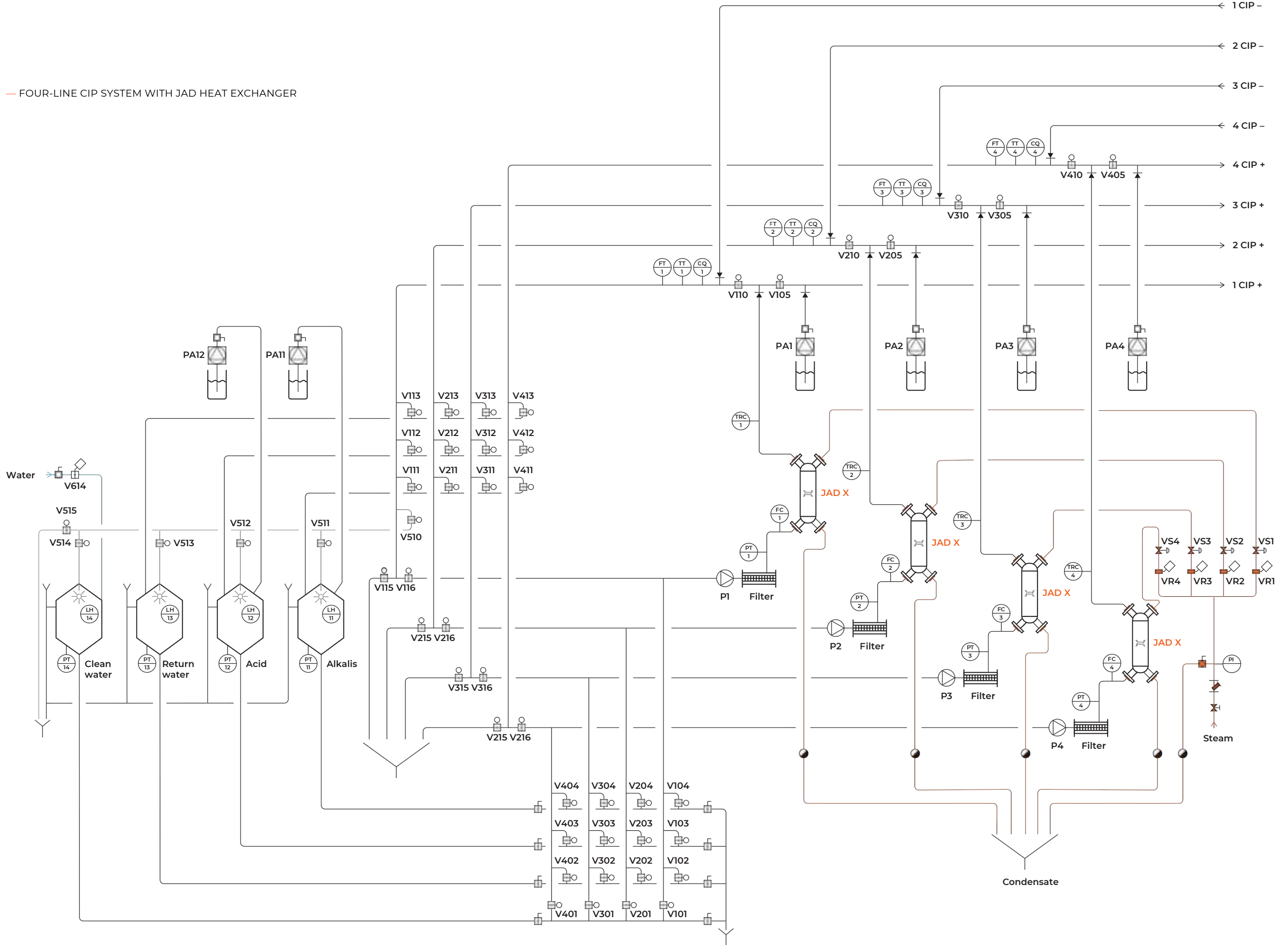

TECHNICAL SUPPORT AND EXPERT CONSULTATION

At Hexonic, we are pleased to share our knowledge and nearly 40 years of experience in manufacturing heat exchangers. We help our customers choose the right solutions—even for demanding applications like those in the food industry. Our team is here to support you throughout the entire ordering process.

You can reach out to our technical sales support team directly or use our user-friendly selection tool—CAIRO. It helps you choose the right heat exchanger quickly and accurately based on your operating conditions. It also gives you an initial price estimate and a detailed technical datasheet, which you can use to place an order or discuss further with one of our experts.

With a CAIRO account, you can save your projects and access them anytime. The platform also includes 3D STEP files, making it easier to fit the heat exchanger into your system design.

If you need assistance from our technical sales support team, please prepare the following information:

- Type of medium: caustic, acid, water, or disinfectant.
- Flow rate (L/h).
- Temperature or steam pressure.
- Number of cleaning circuits.
- Available installation space and connection type.



cairo.hexonic.com



HOW TO SELECT A HEXONIC HEAT EXCHANGER FOR AGGRESSIVE MEDIA

Selecting a Hexonic heat exchanger for use with aggressive media requires careful analysis of several key factors. The first and most important step is to accurately identify the working medium and its concentration—for example, a 2% NaOH solution will have a significantly different impact on construction materials than a 10% solution.

Equally important are the operating conditions, such as temperature and the duration of contact between the medium and the heat exchanger. These parameters directly affect the rate of corrosion and the overall durability of the equipment.

For highly corrosive media—where maximum chemical resistance and long-term reliability are essential—the recommended solution is to use **HAD** or **JAD** heat exchangers made of high-alloy stainless steels, such as 316L.

In all cases, we strongly recommend consulting Hexonic's technical team. We can help select the right materials using chemical resistance charts and provide expert advice to ensure the heat exchanger is properly matched to your operating conditions and application needs.



EXAMPLE OF HEAT EXCHANGER SELECTION FOR A CIP STATION IN THE FOOD INDUSTRY

In a CIP cleaning station, the heat exchanger is responsible for rapidly heating and maintaining the temperature of cleaning solutions. A properly selected unit ensures effective cleaning, time savings, and reduced downtime. To prevent production delays, the cleaning solution must reach the target temperature before the cleaning cycle begins. Therefore, the exchanger selection must consider tank volume, cycle time, temperature requirements, flow rate, and the type of chemicals used.

An efficient heat exchanger means:

- shorter cleaning cycles
- lower energy consumption
- higher hygiene standards

CIP stations in the food industry typically operate with pumps delivering 30,000–40,000 L/h, and the required heating capacity is approximately 1,200 kW.

Recommended temperature ranges:

- sodium hydroxide (NaOH) cleaning: 70–80°C
- nitric acid (HNO₃) cleaning: 55–65°C

The system's start-up time depends on the tank capacity and involves a brief but intense energy demand necessary to initiate the cleaning process.

CIP STATION OPERATING PARAMETERS

Parameter	Value / Range
Tanks – Quantity	3–4
Tanks – Capacity	1–10 m ³
Pumps – Average flow rate	10–60 m ³ /h
Flow velocity in CIP installation	1–2 m/s
Flow velocity in the cleaned object's piping	1,5–2,5 m/s
Connections	<ul style="list-style-type: none"> – Tri Clamp – Milk Connection – Flange – For welding

TECHNICAL ASSUMPTIONS

Parameter	Value / Range
Heat exchanger	JAD X 9.88.08.65
Flow rate	30 000 L/h
Steam pressure	4 bar
Power	1 MW

SHELL AND TUBE HEAT EXCHANGERS USED FOR HEATING DETERGENTS IN CIP CLEANING STATIONS

Type of shell-and-tube heat exchanger	Diameter of CIP connection (shell)	Maximum flow of detergents, m ³ /h
H0K, H1K	External thread G 3/4" (Flange DN20)	3.2
H2K	External thread G 1" (Flange DN25)	5.3
JAD X 2.11, HAD 2.11	Flange DN40	8.6
JAD X 3.18, HAD 3.18	Flange DN50	12.2
S0X, S1X, HAD S0, HAD S1	Flange DN40	15
JAD X 5.38, HAD 5.38	Flange DN65	23
JAD X 6.50, HAD 6.50	Flange DN80	32
JAD X 9.88, HAD 9.88	Flange DN100	57
JAD X 12.114, HAD 12.114	Flange DN125	88

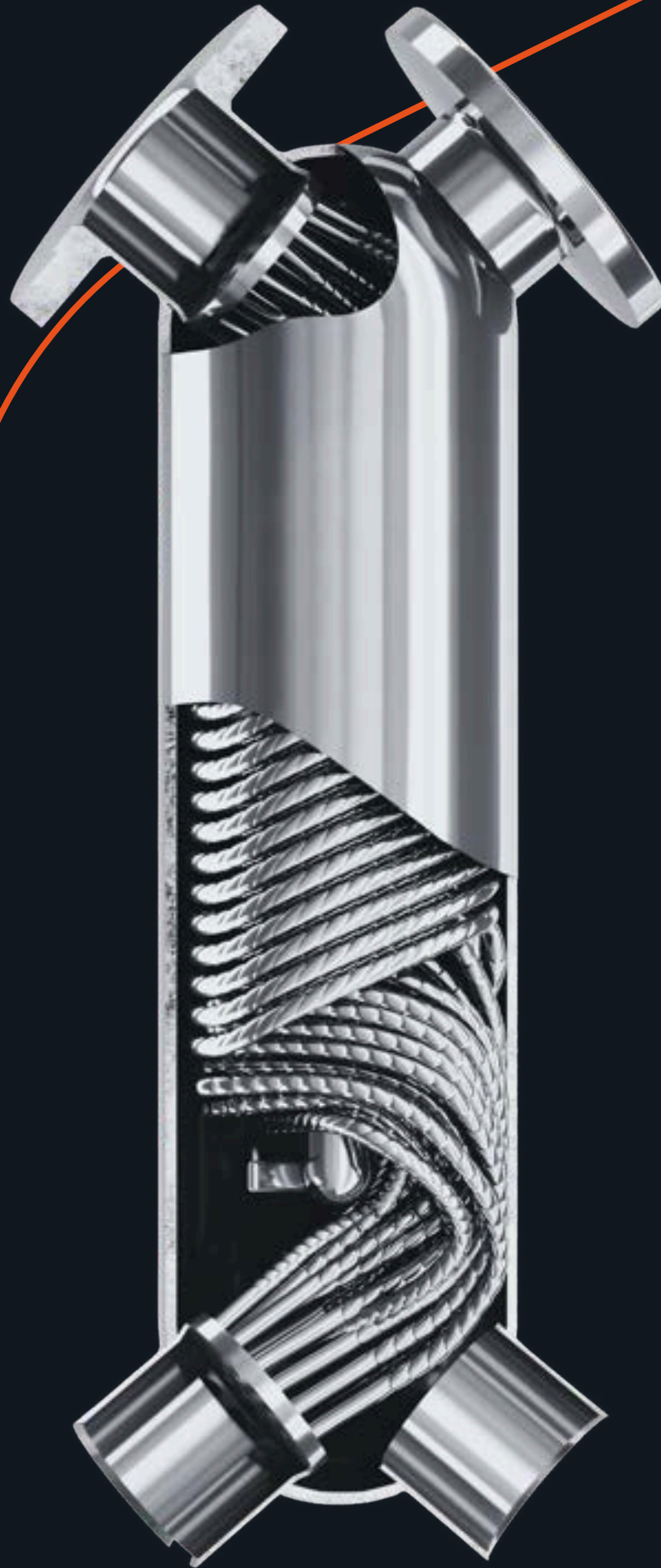

MAINTENANCE OF JAD AND HAD HEAT EXCHANGERS IN CIP SYSTEMS

How often does the heat exchanger require cleaning or inspection?

The inspection and cleaning frequency of JAD and HAD heat exchangers depends on the type of medium, operating conditions, and the quality of the fluid flowing through the unit. For CIP systems, periodic inspections are recommended at individually determined intervals – typically every 6 to 12 months. For media with a high level of contamination or continuous operation, inspections may be required more frequently.

Can the JAD/HAD heat exchanger be cleaned using the CIP method?

The design of JAD and HAD heat exchangers – thanks to the use of spirally coiled tubes with smooth or corrugated surfaces – allows for effective internal cleaning using CIP systems without the need to disassemble the unit. The turbulent flow supports self-cleaning, and all surfaces in contact with the medium are made of stainless steel, ensuring high resistance to cleaning agents and corrosion.

Are service kits (gaskets, tools) available?

JAD and HAD heat exchangers have a welded, non-dismantlable design, so they do not require replacement of internal gaskets or specialized service tool kits. However, additional accessories are available, such as thermal insulation (e.g., AMWI or PFI) and dedicated mounting supports. For HAD-type exchangers, insulation and supports are factory-installed.

Does the company offer support for commissioning and servicing?

Yes. Hexonic provides comprehensive technical support during the selection, commissioning, and operation of heat exchangers. Technical specialists and service advisors are available to assist customers with CIP system commissioning as well as diagnosing and resolving potential operational issues.

HAD

TECHNICAL DATA

TYPE	Connection type (shell side - CIP)	Max. detergent flow rate, m ³ /h	Dimensions					Heat transfer surface area	Tube diameter	Weight	Tube side volume	Shell side volume
			A	B	C	D	Dz					
H0K	G 3/4" (Flange DN20)	3.2	100	418	585	-	80	0.29	8	7.1	0.5	1
H1K	G 3/4" (Flange DN20)	3.2	110	618	800	-	101.6	0.8	8	10.3	1.1	2.4
H2K	G 1" (Flange DN25)	5.3	110	890	1060	-	101.6	1.32	8	13.4	1.9	3
S0	Flange DN40	15	401	938	1168	300	139.7	2.3	8	35	3.6	6.5
S1	Flange DN40	15	403	1020	1250	320	159	3.1	8	42	4.6	9.9
5.38	Flange DN65	23	450	1544	1849	305	139.7	4.3	8	66	9.5	12.8
5.38.08.71	Flange DN65	23	450	944	1,249	305	139.7	2.3	8	47.6	6.6	8.9
6.50	Flange DN80	32	497	1545	1893	320	159	5.5	8	78.5	12.9	19.1
6.50.08.72	Flange DN80	32	497	960	1308	320	159	3	8	57	9.2	14
6.50.10	Flange DN80	32	497	1,545	1,893	320	159	4.7	10	74.9	13.9	18.5
9.88	Flange DN100	57	604	1552	1972	385	219.1	10.6	8	120.6	25	38.3
9.88.08.65	Flange DN100	57	604	956	1376	385	219.1	4.9	8	81.8	16.8	29.1
9.88.08.85	Flange DN100	57	604	1156	1576	385	219.1	6.3	8	95	18.8	33.4
9.88.10	Flange DN100	57	604	1552	1972	385	219.1	7.7	10	110.8	24.6	36.5
12.114	Flange DN125	88	670	1736	2174	435	273	18.2	8	187.8	41.4	67.6
12.114.08.50	Flange DN125	88	670	834	1272	435	273	5.8	8	100.6	23.4	43
12.114.08.60	Flange DN125	88	670	934	1372	435	273	6.4	8	107.1	24.2	47.3
12.114.08.75	Flange DN125	88	670	1084	1522	435	273	8.8	8	123.3	27.7	50.7
12.114.10	Flange DN125	88	670	1736	2174	435	273	18.6	10	193.8	51.1	53.2

* Product dimensions and technical parameters are approximate and subject to change without notice.

The table presents HAD heat exchangers dedicated to CIP applications. A wider range of this series is available in the corresponding product catalog, CAIRO, or on the website hexonic.com.

EXAMPLE CONNECTION LOCATION (COUNTERFLOW):

K1/K4 — inlet / outlet side 1

K3/K2 — inlet / outlet side 2

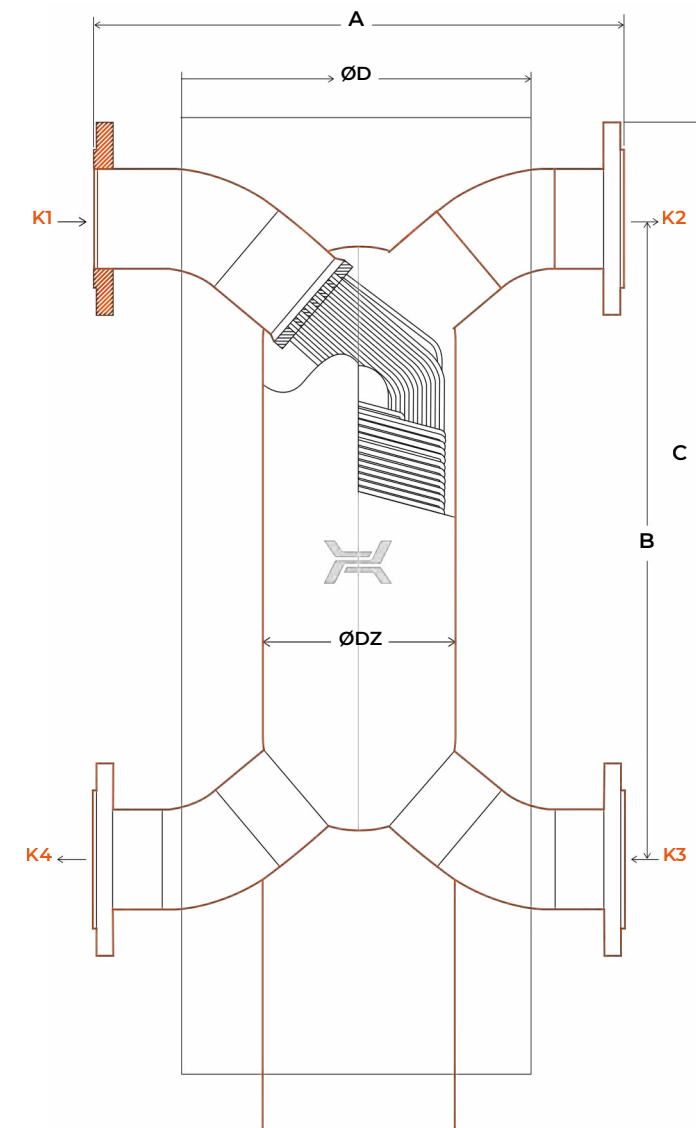

WORKING PARAMETERS

- max. temp.: 250°C
- min. temp.: -20°C
- max. pressure: tube side: 35 bar shell side: 16 bar

JAD

TECHNICAL DATA

TYPE	Connection type (shell side - CIP)	Max. detergent flow rate, m ³ /h	Dimensions						Heat transfer surface area	Tube diameter	Weight	Tube side volume	Shell side volume
			A	B	C	D	Dz	Alfa					
50X	Flange DN40	15	204	911	1026	300	139.7	100	2.3	8	19	3.3	6.2
51X	Flange DN40	15	206	993	1108	302	159	100	3.1	8	22	4.5	9.8
5.38	Flange DN65	23	201	1510	1649	317	139.7	100	4	8	42.4	6.6	11.2
5.38.08.71	Flange DN65	23	201	908	1047	317	139.7	100	2.3	8	30.5	4	6.8
6.50	Flange DN80	32	206	1492	1653	341	159	100	5.3	8	51.9	11.2	13.6
6.50.08.72	Flange DN80	32	206	907	1,068	341	159	100	3.1	8	37.3	4.6	9.9
6.50.10	Flange DN80	32	206	1,492	1,653	341	159	100	5.1	10	50.9	14.2	10.6
9.88	Flange DN100	57	253	1481	1645	390	219.1	100	10.7	8	84.2	16	29
9.88.08.65	Flange DN100	57	253	886	1050	416	219.1	100	4.9	8	52.1	6.6	20.8
9.88.08.85	Flange DN100	57	253	1086	1250	416	219.1	100	6.2	8	60.1	8.2	25
9.88.10	Flange DN100	57	253	1481	1676	416	219.1	100	8.3	10	76.2	13	32
12.114	Flange DN125	88	344	1681	1883	484	273	110	18.4	8	140.2	20.1	54.2
12.114.08.50	Flange DN125	88	344	781	983	484	273	110	6.3	8	71.2	8	29
12.114.08.60	Flange DN125	88	344	881	1083	484	273	110	6.5	8	73.8	9	34
12.114.08.75	Flange DN125	88	344	1031	1233	484	273	110	8.8	8	86.6	10	38.5
12.114.10	Flange DN125	88	344	1681	1883	484	273	110	14.9	10	127.7	19.3	55

* Weight for FF version with flanges

Product dimensions and technical parameters are approximate and subject to change without notice.

The table presents JAD heat exchangers dedicated to CIP applications. A wider range of this series is available in the corresponding product catalog, CAIRO, or on the website hexonic.com.

EXAMPLE CONNECTION LOCATION (COUNTERFLOW):

K1/K4 — inlet / outlet side 1

K3/K2 — inlet / outlet side 2

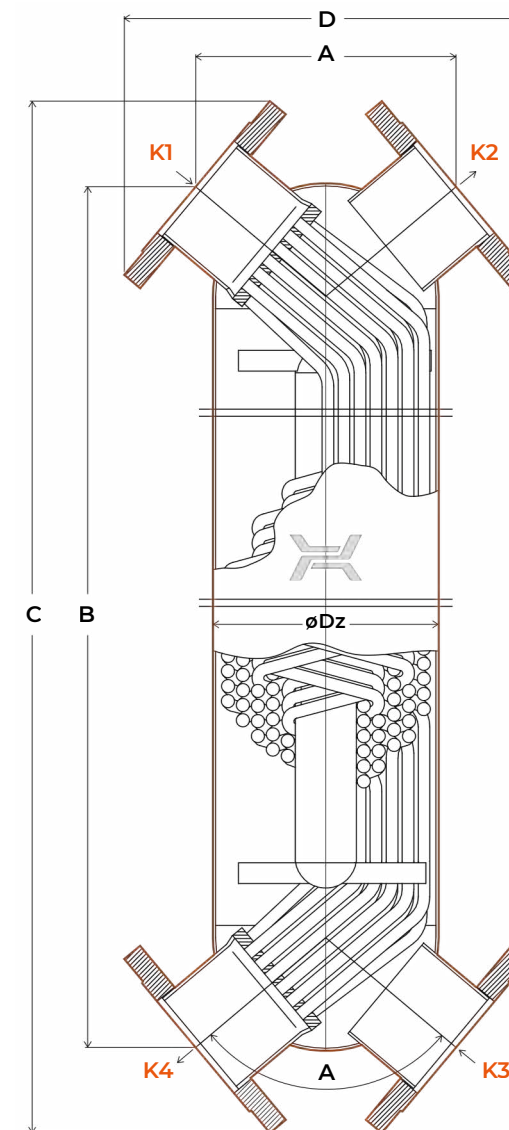

WORKING PARAMETERS

TUBES

- max. temp.: 250° C
- max. pressure: 35 bar

SHELL

- max. temp.: 200°C
- max. pressure: 16 bar

