



# DNA

SHELL & TUBE  
HEAT EXCHANGER

# DNA

## SHELL & TUBE

## HEAT EXCHANGER

DNA heat exchangers represent next step in the evolution of tubular heat exchangers.

They deliver significant benefits in the areas of fluid dynamics and heat transfer while maintaining the features and benefits of traditional shell & tube design.

Thanks to its special geometry, the heat transfer coefficient in the tube side achieves up to double values. This advantage can be used for high viscosity media to increase the overall performance of the unit.



DNA achieves significantly higher heat transfer rates comparing to standard solution.

The design of the unit allows for more efficient operation in high volume applications (e.g. flue gas, hot air, low pressure steam).

The construction of the DNA heat exchanger enables to obtain smaller and lighter device. At the same time, the exchanger retains all the advantages of the shell & tube heat exchanger, especially its high mechanical strength.



# DNA TUBE BUNDLE FEATURES



1

Effective turbulent vortex flow increases heat transfer coefficient up to double values due to helical tube geometry.

2

Effective heat transfer area with more homogeneous distribution of flow and velocity field.

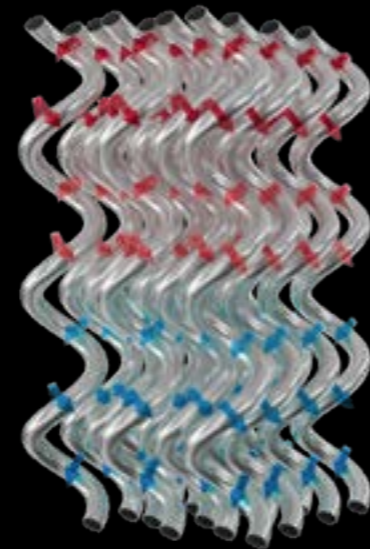

3

Flexible tube bundle, low pressure drop, no dead spots, baffle-free, no need of shell compensator and elimination of vibration due to the multiple contact points along the tube bundle.

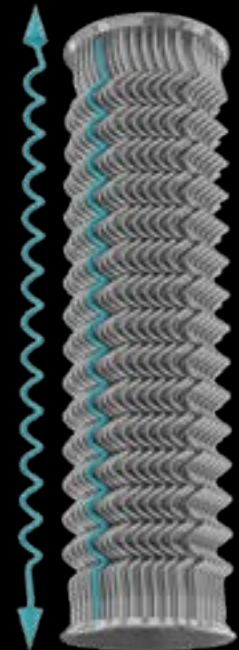

# DNA HEAT EXCHANGER ADVANTAGES



EFFECTIVE HEAT TRANSFER AREA



TURBULENT VORTEX FLOW



LOW PRESSURE DROP



LARGE HEAT TRANSFER AREA CONTAINED IN COMPACT CONSTRUCTION



MADE OF STAINLESS STEEL



RESISTANT TO CORROSION

## TECHNICAL DATA

**K4 / K1** – inlet / outlet cold side

**K2 / K3** – inlet / outlet hot side

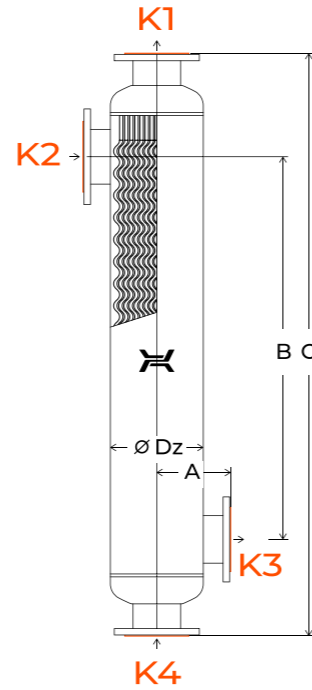

## TECHNICAL PARAMETERS

Type	Mass		Tube side capacity		Shell side capacity		Dimensions							
	kg	lb	l	gal	l	gal	A		B		C		Ø Dz	
							mm	in	mm	in	mm	in	mm	in
DNA 159.10.S24	42,2	92,9	6,7	1,8	13,2	3,5	140	5,5	850	33,2	1260	49,1	159	6,2
DNA 159.10.S37	63,0	138,8	8,8	2,3	19,0	5,0	140	5,5	1350	52,7	1760	68,6	159	6,2
DNA 159.10.S49	77,5	170,9	10,8	2,9	25,9	6,8	140	5,5	1850	72,2	2260	88,1	219	6,2
DNA 219.10.S47	77,4	170,6	13,3	3,5	25,9	6,8	185	7,2	815	31,8	1297	50,6	219	8,5
DNA 219.10.S72	101,6	223,9	17,4	4,6	37,2	9,8	185	7,2	1315	51,3	1797	70,1	219	8,5
DNA 219.10.S96	125,8	277,2	21,5	5,7	48,5	12,8	185	7,2	1815	70,8	2297	89,6	219	8,5
DNA 273.10.S74	110,9	244,5	21,7	5,7	40,9	10,8	216	8,4	785	30,6	1371	53,5	273	10,6
DNA 273.10.S114	145,3	320,2	28,1	7,4	59,0	15,6	216	8,4	1285	50,1	1871	73,0	273	10,6
DNA 273.10.S151	179,5	395,6	34,4	9,1	77,0	20,3	216	8,4	1785	69,6	2371	92,5	273	10,6
DNA 324.10.S110	150,4	331,4	33,0	8,7	59,2	15,6	236	9,2	785	30,6	1384	54,0	324	12,6
DNA 324.10.S168	197,6	435,5	42,6	11,2	80,1	21,1	236	9,2	1285	50,1	1884	73,5	324	12,6
DNA 324.10.S224	244,8	539,6	52,2	13,8	104,8	27,7	236	9,2	1785	69,6	2384	93,0	324	12,6
DNA 406.10.S181	235,8	519,6	59,2	15,6	87,0	23,0	271	10,6	720	28,1	1438	56,1	406	15,8
DNA 406.10.S277	307,6	677,9	75,1	19,8	125,5	33,1	271	10,6	1220	47,6	1938	75,6	406	15,8
DNA 406.10.S369	379,5	836,3	91,0	24,0	164,0	43,3	271	10,6	1720	67,1	2438	95,1	406	15,8
DNA 508.10.S296	392,3	864,6	95,5	25,2	135,0	35,6	340	13,3	660	25,7	1511	58,9	508	19,8
DNA 508.10.S446	511,7	1127,9	121,5	32,1	193,0	51,0	340	13,3	1160	45,2	2011	78,4	508	19,8
DNA 508.10.S610	631,4	1391,7	147,4	38,9	251,0	66,3	340	13,3	1660	64,7	2511	97,9	508	19,8
DNA 550.10.S770	768,0	1692,7	182,9	48,3	297,4	78,5	380	14,8	1600	62,4	2600	101,4	550	21,5

All dimensions and technical data are approximate only and may be changed without further notice.

## INSTALLATION TYPES

DNA heat exchangers can be installed **vertically** or **horizontally** depending on the application and available space.

## CONNECTION TYPE

Type	Flange							
	K1	K2	K3	K4				
DNA 159.10.S24	DN 80	3"	DN 100	4"	DN 80	3"	DN 80	3"
DNA 159.10.S37	DN 80	3"	DN 100	4"	DN 80	3"	DN 80	3"
DNA 159.10.S49	DN 80	3"	DN 100	4"	DN 80	3"	DN 80	3"
DNA 219.10.S47	DN 100	4"	DN 125	5"	DN 100	4"	DN 100	4"
DNA 219.10.S72	DN 100	4"	DN 125	5"	DN 100	4"	DN 100	4"
DNA 219.10.S96	DN 100	4"	DN 125	5"	DN 100	4"	DN 100	4"
DNA 273.10.S74	DN 125	5"	DN 150	6"	DN 125	5"	DN 125	5"
DNA 273.10.S114	DN 125	5"	DN 150	6"	DN 125	5"	DN 125	5"
DNA 273.10.S151	DN 125	5"	DN 150	6"	DN 125	5"	DN 125	5"
DNA 324.10.S110	DN 125	5"	DN 150	6"	DN 125	5"	DN 125	5"
DNA 324.10.S168	DN 125	5"	DN 150	6"	DN 125	5"	DN 125	5"
DNA 324.10.S224	DN 125	5"	DN 150	6"	DN 125	5"	DN 125	5"
DNA 406.10.S181	DN 150	6"	DN 200	8"	DN 150	6"	DN 150	6"
DNA 406.10.S277	DN 150	6"	DN 200	8"	DN 150	6"	DN 150	6"
DNA 406.10.S369	DN 150	6"	DN 200	8"	DN 200	8"	DN 150	6"
DNA 508.10.S296	DN 150	6"	DN 250	10"	DN 200	8"	DN 150	6"
DNA 508.10.S446	DN 150	6"	DN 250	10"	DN 200	8"	DN 150	6"
DNA 508.10.S610	DN 150	6"	DN 250	10"	DN 200	8"	DN 150	6"
DNA 550.10.S770	DN 200	8"	DN 300	12"	DN 250	10"	DN 200	8"

# SHELL & TUBE HEAT EXCHANGER

## APPLICATION

- low pressure steam condensers (flash steam condensers)
- industrial and chemical processes
- recuperation and regeneration in industrial technologies
- waste heat recovery – diesel and gas engines, cogeneration systems
- water and steam systems, cooling circuits

## CONSTRUCTION

- heat transfer area created by identical helical tubes of diameter  $\varnothing$  0.39 in / 10 mm
- many contact points along the tubes provide high resistance of tube bundle against possible vibrations
- non-baffle design with a homogeneous tube-bundle

## WORKING PARAMETERS

- max. temp.: 392°F / 200°C
- min. temp.: -4°F / -20°C
- max. pressure shell side: 145 psi / 10 bar
- max. pressure tube side: 232 psi / 16 bar

## MATERIAL TYPE

stainless steel AISI 316L / 1.4404

## MEDIA

water, steam, glycol, flue gas, air, ammonia, acetone, toluene, synthetic oils and other media after consulting the manufacturer

## CERTIFICATES

manufactured in accordance with PED, ASME, EAC, China ML