

HAD

SHELL & COIL
HEAT EXCHANGERS



HAD HEAT EXCHANGERS

HAD shell and coil exchanger is a fully equipped, installation-ready kit consisting of an exchanger, mount and insulation.

As a result of advanced design works, HAD has all the benefits of the shell and coil exchangers plus new solutions such as the horizontal position of the connections; it also comes with an insulation and a mount.

The new HAD features facilitate mounting it to a horizontal installation and shorten the whole process. Additionally HAD is a perfect solution in terms of economy, ensuring a cost-efficient solution.



WHY CHOOSE **HEXONIC** HAD SHELL & COIL HEAT EXCHANGERS?



COMPACT SIZE

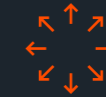

LARGE HEAT EXCHANGE AREA



LOW MAINTENANCE COSTS



RESISTANCE TO HIGH TEMPERATURE AND PRESSURE



HIGH PERFORMANCE



FACTORY-INSTALLED INSULATION



TURBULENT FLOW PROMOTED BY CORRUGATION OF TUBES



VERTICAL INSTALLATION REDUCES SPACE REQUIREMENTS



MANUFACTURED IN ACCORDANCE WITH ASME BPVC SECTION VIII, DIV. 1



USER-FRIENDLY CAIRO SELECTION SOFTWARE MAKES THE SELECTION PROCESS EASY



WIDE RANGE OF PRODUCTS

HAD CONSTRUCTION

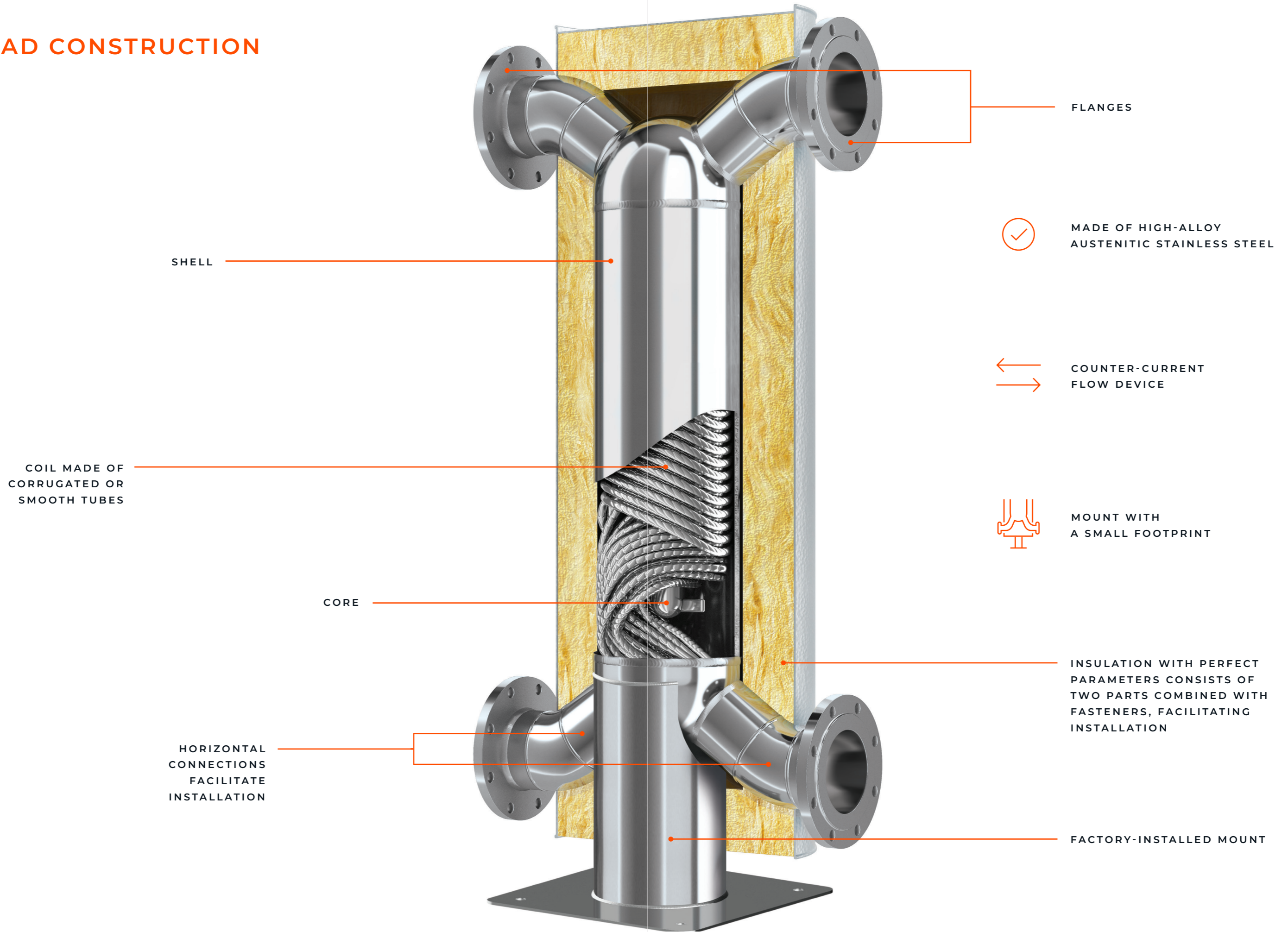

SHELL

COIL MADE OF CORRUGATED OR SMOOTH TUBES

CORE

HORIZONTAL CONNECTIONS FACILITATE INSTALLATION

FLANGES



MADE OF HIGH-ALLOY AUSTENITIC STAINLESS STEEL



COUNTER-CURRENT FLOW DEVICE



MOUNT WITH A SMALL FOOTPRINT

INSULATION WITH PERFECT PARAMETERS CONSISTS OF TWO PARTS COMBINED WITH FASTENERS, FACILITATING INSTALLATION

FACTORY-INSTALLED MOUNT



APPLICATION



HVAC SYSTEMS



STEAM APPLICATIONS



HEATING AND COOLING SYSTEMS



HEAT TRANSFER IN INDUSTRIAL PROCESSES



OIL COOLERS

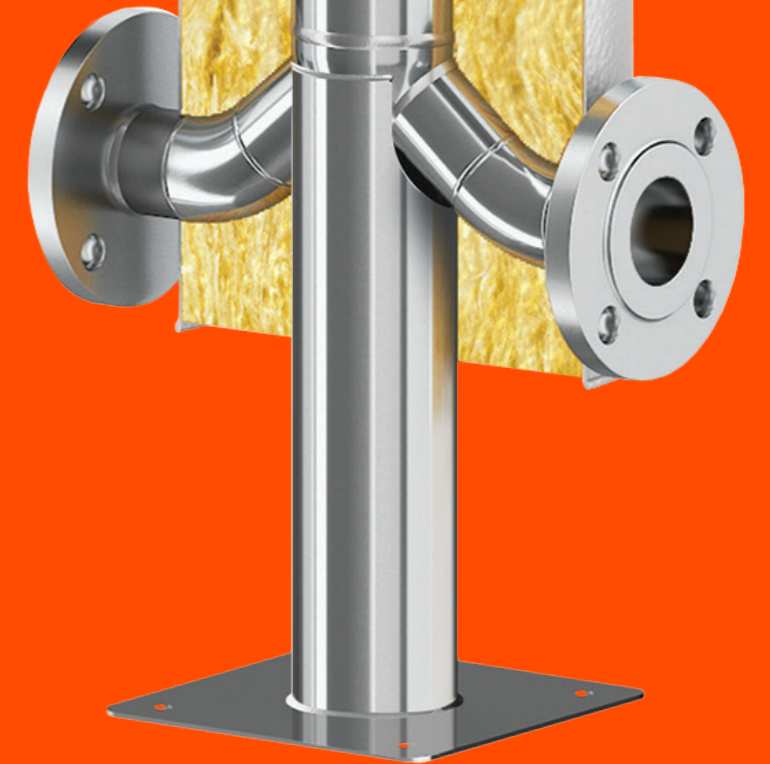

TECHNICAL DATA

STANDARD LOCATION OF CONNECTIONS

K1 / K4 — inlet / outlet hot side
 K3 / K2 — inlet / outlet cold side

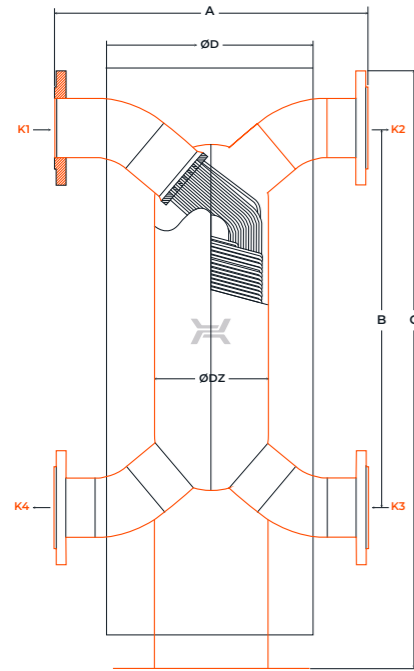

- HAD 2.11.08.68 UM
- HAD 2.11 UM
- HAD 3.18.08.75 UM
- HAD 3.18 UM
- HAD 5.38.08.71 UM
- HAD 5.38 UM
- HAD 6.50.08.72 UM
- HAD 6.50 UM
- HAD 9.88.08.65 UM
- HAD 9.88.08.85 UM
- HAD 9.88 UM
- HAD 12.114.08.50 UM
- HAD 12.114.08.60 UM
- HAD 12.114.08.75 UM
- HAD 12.114 UM

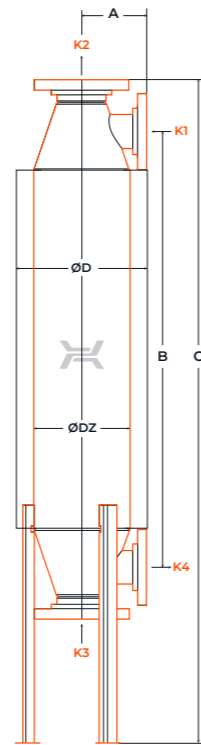

HAD 14.163.UM

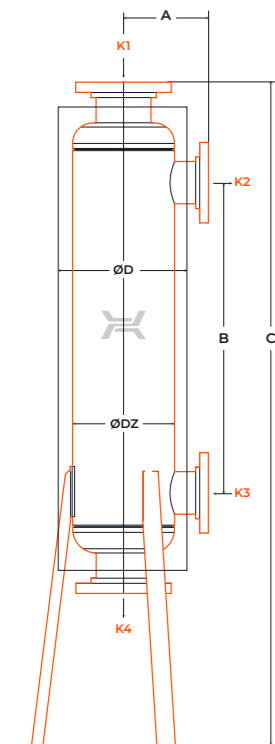

HAD 15.177.10.U
 HAD 15.177.10.75.UM
 HAD 15.177.10.100.U

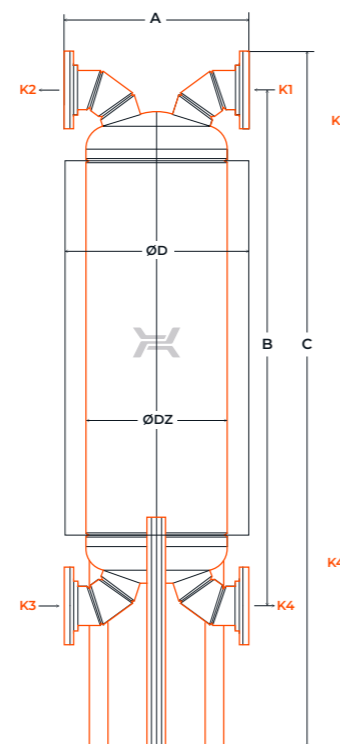

HAD 17.217.U

MATERIALS

- TUBES AND SHELL – STAINLESS STEEL 316L
- FLANGES – STAINLESS STEEL 304L

EXEMPLARY MEDIA

- WATER
- STEAM
- OTHER

WORKING PARAMETERS

MAX. TEMPERATURE — 482°F
 MIN. TEMPERATURE — -4°F

MAX. PRESSURE — 363 PSI

TECHNICAL PARAMETERS

Type	Dimensions					Heat exchange area	Tube diameter	Weight	Tube side capacity	Shell side capacity
	A	B	C	D	ØDz					
	in	in	in	in	in	ft²	in	lb	gal	gal
HAD 2.11.08.68 UM	13.7	33.9	43.1	10	3.1	6.5	0.3	47	0.4	0.4
HAD 2.11 UM	13.7	60.4	69.6	10	3.1	12.9	0.3	60	0.8	0.8
HAD 3.18.08.75 UM	15.1	37.3	47.7	10.4	4	12.9	0.3	66	0.8	0.8
HAD 3.18 UM	15.1	60.6	71	10.4	4	21.5	0.3	86	1.5	1.5
HAD 5.38.08.71 UM	17.7	37.1	49.5	12	5.6	24.7	0.3	101	1.3	2.1
HAD 5.38 UM	17.7	60.8	73.2	12	5.6	43	0.3	134	2	3.3
HAD 6.50.08.72 UM	19.5	37.8	52.2	12.6	6.3	33.4	0.3	141	1.7	3.1
HAD 6.50 UM	19.5	60.8	75.2	12.6	6.3	57	0.3	181	2.11	5.5
HAD 9.88.08.65 UM	23.8	37.7	54.9	15.2	8.6	52.7	0.3	240	2.6	6.4
HAD 9.88.08.85 UM	23.8	45.5	62.8	15.2	8.6	66.7	0.3	269	3	7.5
HAD 9.88 UM	23.8	61.1	78.3	15.2	8.6	115.1	0.3	344	5.1	8.6
HAD 12.114.08.50 UM	26.4	32.9	50.6	17.5	10.7	67.8	0.3	313	3.1	9.1
HAD 12.114.08.60 UM	26.4	36.8	54.6	17.5	10.7	69.9	0.3	324	3.4	10.5
HAD 12.114.08.75 UM	26.4	42.8	60.5	17.5	10.7	94.7	0.3	362	3.6	11.7
HAD 12.114 UM	26.4	68.3	86	17.5	10.7	198	0.3	518	6.3	15.9
HAD 14.163.UM	8.66	57.76	88.11	17.99	12.75	258	0.315	452	10.4	12.84
HAD 15.177.10.U	13.39	48.62	103.9	20.02	16	382	0.394	1135	21.42	34.03
HAD 15.177.10.75.UM	13.39	19.09	74.41	20.02	16	177	0.394	705	13.68	17.17
HAD 15.177.10.100.U	13.39	28.94	84.25	20.02	16	242	0.394	848	17.3	24.04
HAD 17.217.U	26.38	73.03	98.48	26.73	20	628	0.315	987	22.48	63.4

All dimensions and technical data are approximate only and may be changed without further notice.

CONNECTIONS

Type	Connection
HAD 2.11.08.68 UM	1 ½"
HAD 2.11 UM	1 ½"
HAD 3.18.08.75 UM	2"
HAD 3.18 UM	2"
HAD 5.38.08.71 UM	2 ½"
HAD 5.38 UM	2 ½"
HAD 6.50.08.72 UM	3"
HAD 6.50 UM	3"
HAD 9.88.08.65 UM	4"
HAD 9.88.08.85 UM	4"
HAD 9.88 UM	4"
HAD 12.114.08.50 UM	5"
HAD 12.114.08.60 UM	5"
HAD 12.114.08.75 UM	5"
HAD 12.114 UM	5"
HAD 14.163.UM	K1/K4: 4" CL 300 SORF; K2/K3: 6" CL 300 SORF
HAD 15.177.10.U	K1/K4: 8" CL 300 SORF; K2/K3: 6" CL 300 SORF
HAD 15.177.10.75.UM	K1/K4: 8" CL 300 SORF; K2/K3: 6" CL 300 SORF
HAD 15.177.10.100.U	K1/K4: 8" CL 300 SORF; K2/K3: 6" CL 300 SORF
HAD 17.217.U	K1/K4: 5" CL 300 SORF; K2/K3: 5" CL 300 SORF

Flanges: ASME B 16.5

INSULATION AMWI

MINERAL WOOL INSULATION COVERED WITH ALUMINIUM

- MAX. WORKING TEMPERATURE: 482°F
- THICKNESS: 3.15 IN
- THERMAL CONDUCTIVITY AT MAX. TEMPERATURE: 0.474 BTU/FT



EXEMPLAR DESIGNATION

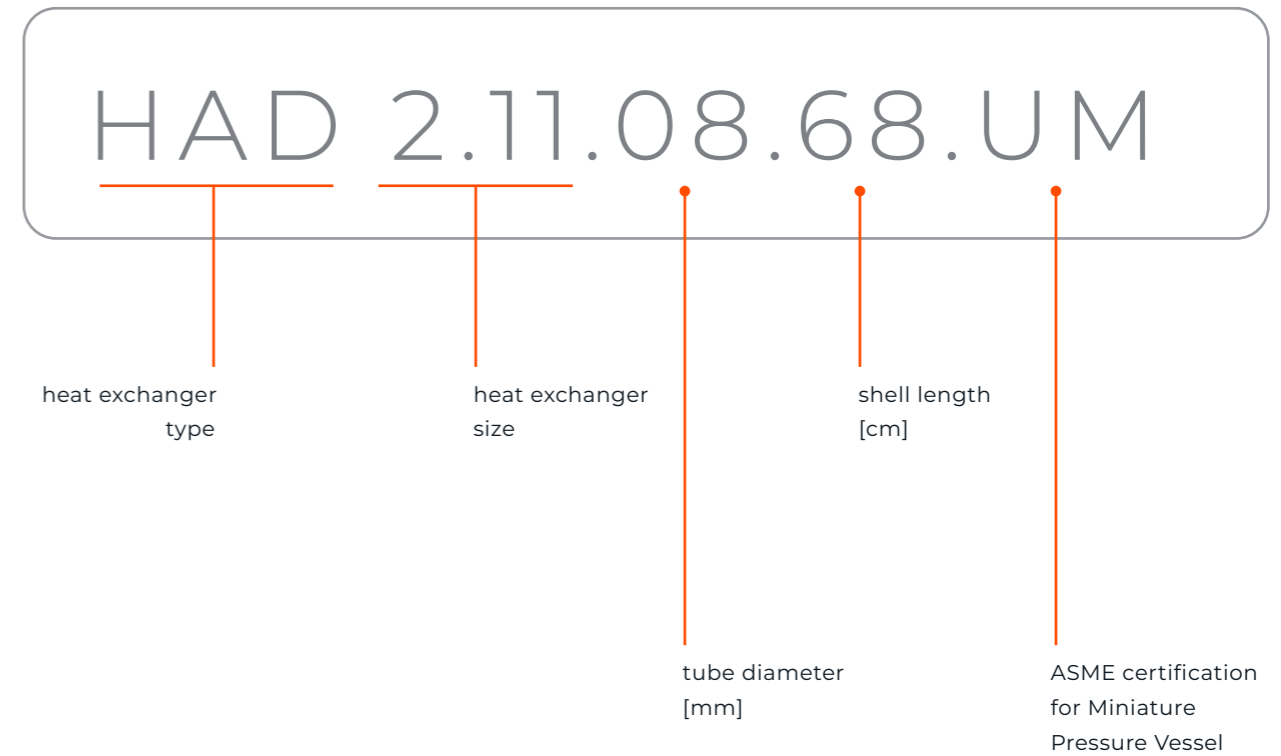

PRODUCT LINE



