

# BPHE

BRAZED PLATE  
HEAT EXCHANGERS



# BRAZED PLATE HEAT EXCHANGERS

Brazed plate heat exchangers are the perfect solution that allows to maintain high thermal performance at low operating costs.

Wide range of types, sizes, and numbers of plates and connections allows for optimizing the selection to particular application.

Copper or stainless brazing and the double wall option offer additional application possibilities. Brazed plate heat exchangers guarantee reliable, long-term operation.



## WHY CHOOSE **HEXONIC** BRAZED PLATE HEAT EXCHANGERS?



### HIGH PERFORMANCE

Heat exchangers are designed for very efficient operations within a wide range of applications. They guarantee compact and flexible solutions.



### WIDE RANGE OF APPLICATIONS

Heat exchangers are used in central heating and domestic hot water systems, ventilation, technological and air-conditioning installations, as well as in heat pumps and ice water generators.



### CERTIFICATES AND STANDARDS

Manufactured in accordance with ASME, UL, PED, EAC.



### RELIABILITY

Advanced technology and high quality materials offer durability and reliability.



### FLEXIBLE DESIGN

We offer 1- or 2-pass versions with a choice of different types of connections such as: dual (external thread / soldering), internal thread, Victaulic, stainless steel flange, carbon steel flange.



### EASY SELECTION

User-friendly CAIRO Selection Software makes the selection process easy.

# L

## BRAZED PLATE HEAT EXCHANGERS

DEDICATED TO HEATING OR COOLING SYSTEMS.

### APPLICATION



DOMESTIC HOT WATER SYSTEMS



CENTRAL HEATING SYSTEMS



SOLAR AND GEOTHERMIC HEATING SYSTEMS



INSTALLATIONS WITH HEAT PUMP



INSTALLATIONS WITH FIREPLACE WITH WATER JACKET

### ADVANTAGES



HIGH HEAT TRANSFER COEFFICIENT



EASY ASSEMBLY AND DISMANTLE



COMPACT SIZE



RESISTANCE TO HIGH TEMPERATURE AND PRESSURE



ASYMMETRIC OPTION AVAILABLE



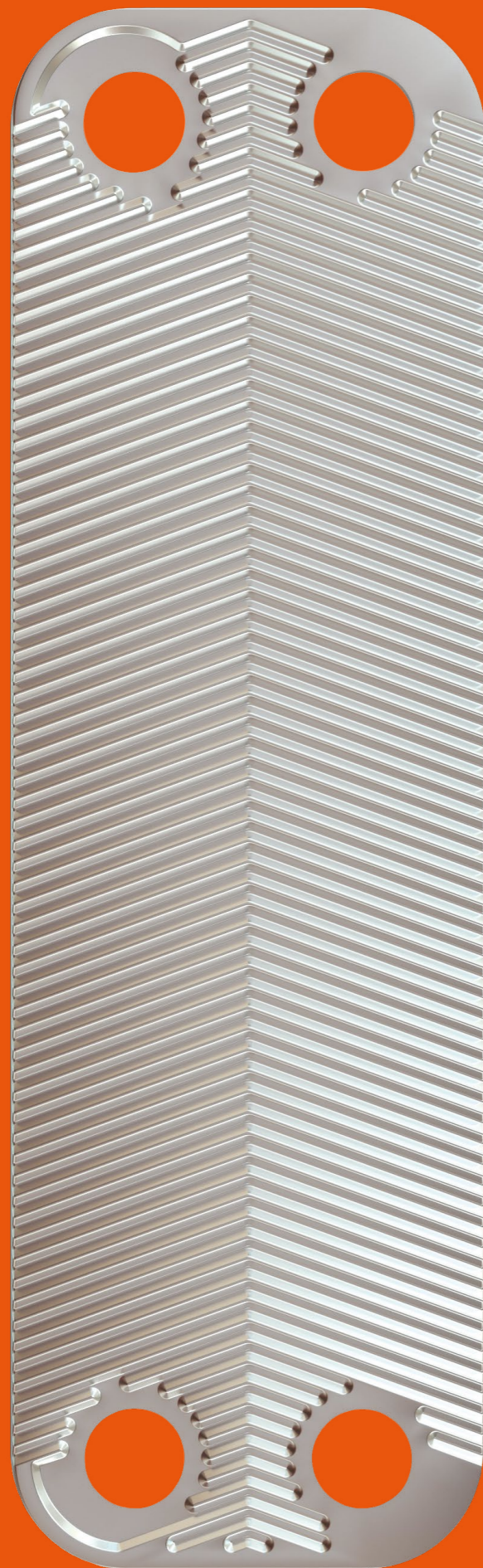

MICROCHANNEL BRAZED  
PLATE HEAT EXCHANGER

8%  
↑

**INCREASE OF HEAT EXCHANGE  
EFFICIENCY BY UP TO 8%**  
COMPARING TO OTHER COMPETITIVE  
MICROCHANNEL HEAT EXCHANGERS

9%  
↓

**REDUCTION OF FLOW  
RESISTANCE BY UP TO 9%**  
COMPARING TO THE MOST  
EFFICIENT MICROCHANNEL HEAT  
EXCHANGER ON THE MARKET

35%  
↑

**INCREASE OF HEAT EXCHANGE  
EFFICIENCY BY 35%**  
COMPARING TO EXCHANGERS  
WITH STANDARD HEAT PLATES



**HIGHER FLOW TURBULENCE  
ENHANCES HEAT EXCHANGE**  
THANKS TO OPTIMIZATION  
OF FLOW VELOCITY

EXEMPLAR DESIGNATION

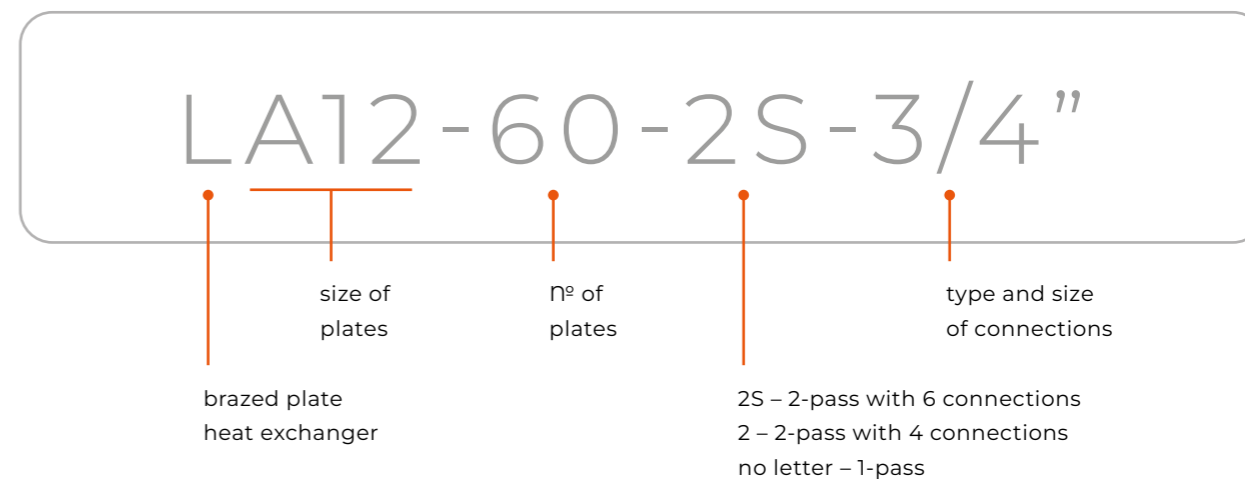

PRODUCT LINE

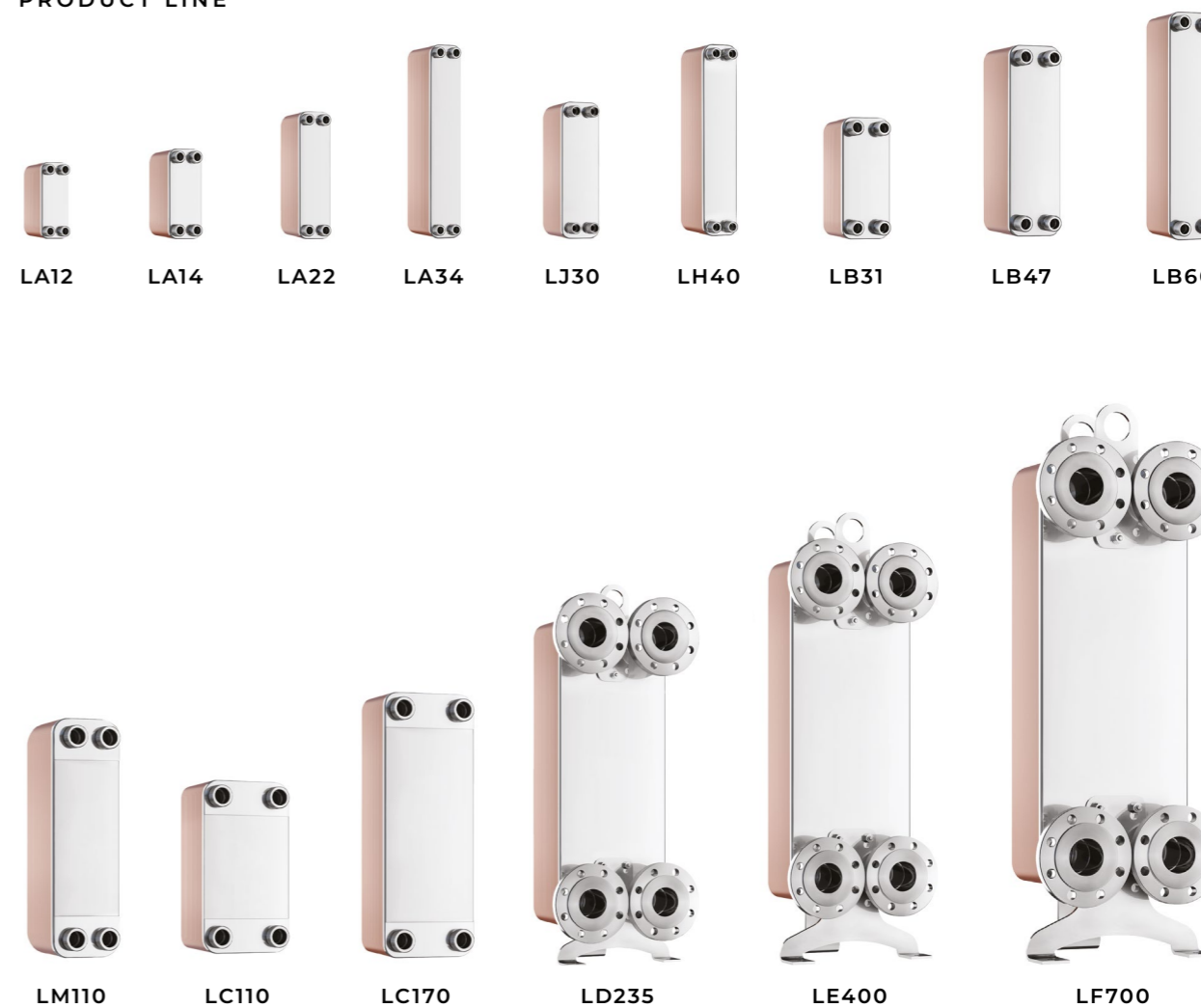

# TECHNICAL DATA

## STANDARD LOCATION OF CONNECTIONS

### 1-PASS HEAT EXCHANGER

- K1 / K4** — inlet / outlet hot side
- K3 / K2** — inlet / outlet cold side

### 2-PASS HEAT EXCHANGER

- D4 / K4** — inlet / outlet hot side
- K3 / D3** — inlet / outlet cold side

### 2-PASS WITH 6 CONNECTIONS

#### ADDITIONALLY:

- K1** — vent connection / inlet of central heating return
- K2** — vent connection / inlet of domestic hot water circulation return

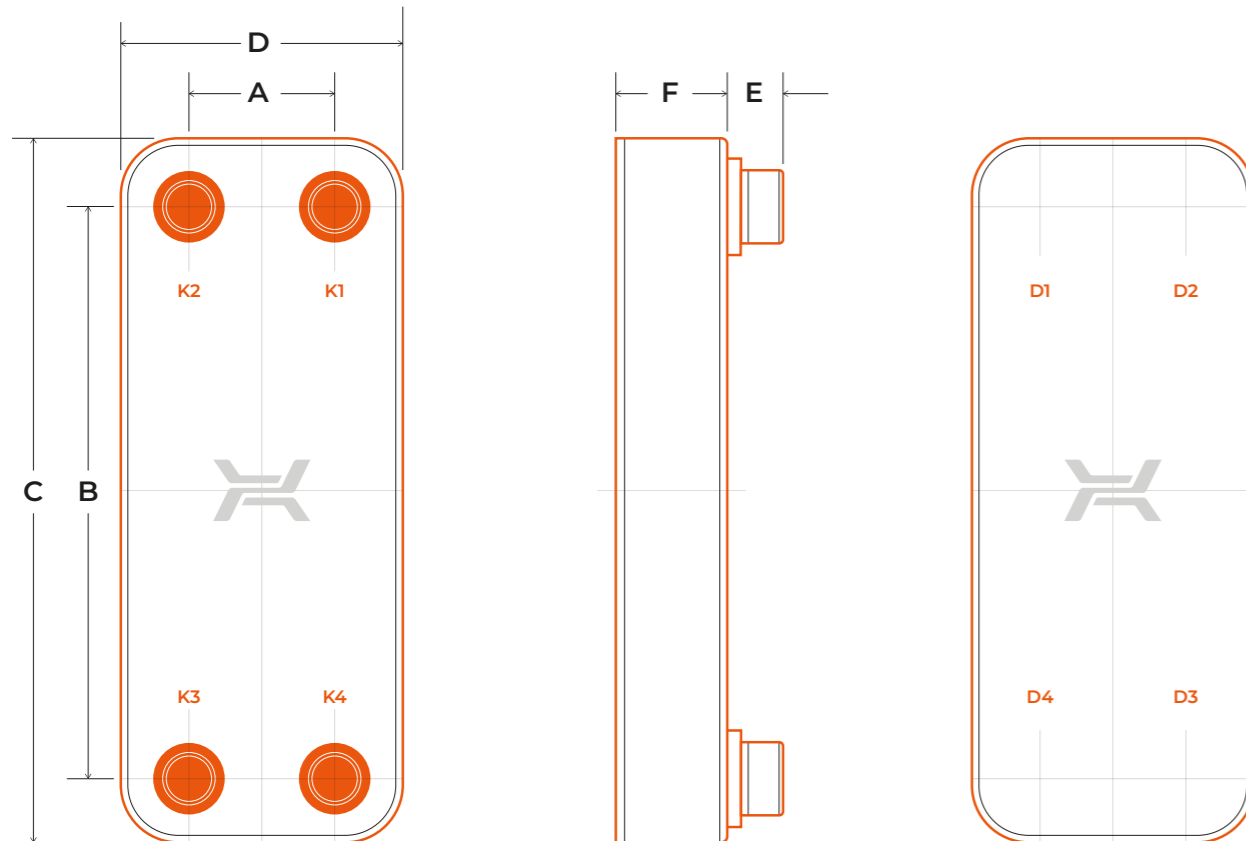

## MATERIALS

- STAINLESS STEEL
- COPPER BRAZING

## EXEMPLARY MEDIA

- WATER
- PROPYLENE GLYCOL SOLUTIONS
- GROUP II FLUIDS
- OTHER (CONSULT THE MANUFACTURER)

## WORKING PARAMETERS

- MAX. TEMPERATURE — 230°C
- LJ — 160°C

- MIN. TEMPERATURE — -195°C
- FOR FLANGE CS — 0°C

## MAX. PRESSURE

- LA, LB, LH — 3 MPA
- LM, LC, LD, LE — 2,5 MPA
- LJ, LF — 1,6 MPA

# TECHNICAL PARAMETERS

Type	Dimensions												max NP	Mass	
	A		B		C		D		E		F			kg	lb
	mm	in	mm	in	mm	in	mm	in	mm	in	mm	in			
LA12	40	1.6	154	6.1	190	7.5	72	2.8	16/20	0.6/0.8	9 + 2.45 × NP	0.35 + 0.10 × NP	60	0.4 + 0.049 × NP	0.88 + 0.11 × NP
LA14	42	1.7	164	6.5	203	8.0	81	3.2	16/20	0.6/0.8	9 + 2.30 × NP	0.35 + 0.09 × NP	60	0.6 + 0.049 × NP	1.32 + 0.11 × NP
LA21AS	40	1.6	278	10.9	314	13.4	73	2.9	14	0.6	11 + 2.3 × NP	0.39 + 0.09 × NP	60	0.58 + 0.06 × NP	1.28 + 0.13 × NP
LA22	42	1.7	260	10.2	299	11.8	81	3.2	16/20	0.6/0.8	9 + 2.30 × NP	0.35 + 0.09 × NP	60	0.8 + 0.073 × NP	1.76 + 0.16 × NP
LA22(X)	42	1.7	260	10.2	299	11.8	81	3.2	16/20	0.6/0.8	9 + 1.9 × NP	0.35 + 0.07 × NP	60	0.8 + 0.073 × NP	1.76 + 0.16 × NP
LA34	42	1.7	432	17.0	471	18.5	81	3.2	16/20	0.6/0.8	9 + 2.30 × NP	0.35 + 0.09 × NP	60	1.2 + 0.116 × NP	2.65 + 0.26 × NP
LJ30	46	1.8	270	10.6	318	12.5	98	3.9	20	0.8	9 + 1.70 × NP	0.35 + 0.07 × NP	60	1.1 + 0.064 × NP	2.43 + 0.14 × NP
LH40	43	1.7	415	16.3	461	18.1	89	3.5	28	1.1	10 + 2.25 × NP	0.39 + 0.09 × NP	60	1.7 + 0.134 × NP	3.75 + 0.30 × NP
LB31	68	2.7	232	9.1	286	11.3	123	4.8	28	1.1	10 + 2.35 × NP	0.39 + 0.09 × NP	150	1.6 + 0.114 × NP	3.53 + 0.25 × NP
LB47	68	2.7	360	14.2	417	16.4	123	4.8	28	1.1	10 + 2.35 × NP	0.39 + 0.09 × NP	150	2.1 + 0.168 × NP	4.63 + 0.37 × NP
LB60	68	2.7	480	18.9	538	21.2	123	4.8	28	1.1	11 + 2.35 × NP	0.43 + 0.09 × NP	150	2.6 + 0.219 × NP	5.73 + 0.48 × NP
LB60(X)	68	2.7	480	18.9	538	21.2	123	4.8	28	1.1	11 + 1.95 × NP	0.43 + 0.077 × NP	150	2.6 + 0.219 × NP	5.73 + 0.48 × NP
LM110	91	3.6	520	20.5	619	24.4	190	7.5	48	1.9	10 + 2.60 × NP	0.39 + 0.10 × NP	200	8.4 + 0.408 × NP	18.52 + 0.90 × NP
LC110	170	6.7	378	14.9	466	18.4	258	10.2	28/38; 100	1.1/1.5; 3.9	11 + 2.40 × NP	0.43 + 0.09 × NP	200	8.7 + 0.408 × NP	19.18 + 0.90 × NP
LC110AS	170	6.7	378	14.9	466	18.4	258	10.2	28/38; 100	1.9	11 + 2.40 × NP	0.39 + 0.09 × NP	200	8.7 + 0.408 × NP	19.18 + 0.90 × NP
LC170	170	6.7	600	23.6	688	27.1	258	10.2	28/38; 100	1.1/1.5; 3.9	11 + 2.40 × NP	0.43 + 0.09 × NP	200	11.5 + 0.617 × NP	25.35 + 1.36 × NP
LD235	204	8.0	682	26.9	788	31.0	310	12.2	100	3.9	13 + 2.5 × NP	0.51 + 0.10 × NP	280	40 + 0.828 × NP	88.18 + 1.83 × NP
LE400	240	9.5	861	33.9	1008	39.7	387	15.2	93	3.7	17 + 2.75 × NP	0.67 + 0.11 × NP	400	74.3 + 1.625 × NP	163.80 + 3.58 × NP
LF700	325	12.8	1100	43.31	1327	52.24	552	21.72	115	5.51	19 + 2.3 × NP	0.75 + 0.09 × NP	400	159.2 + 3.35 × NP	406.97 + 7.39 × NP

NP – number of plates | dim. F+/-3%.

All dimensions and technical data are approximate only and may be changed without further notice.

Mass is given for 1-pass heat exchangers.

# LUNA

**BRAZED PLATE HEAT EXCHANGERS**  
ENTIRELY MADE OF STAINLESS  
MATERIALS DESIGNED TO MAINTAIN  
HIGH SANITARY STANDARDS.

## APPLICATION

WHEN HIGH LEVEL  
OF HYGIENE IS CRUCIAL



SYSTEMS WITH  
DEMINERALIZED WATER



DOMESTIC HOT  
WATER SYSTEMS



COOLING SYSTEMS  
WITH HIGH HYGIENIC  
STANDARDS

WHEN RELIABILITY  
IS ESSENTIAL



CENTRAL HEATING  
SYSTEMS



SYSTEMS WITH  
AGGRESSIVE MEDIA

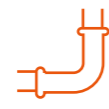

SYSTEMS WITH  
GALVANIZED PIPES



INDUSTRIAL  
COOLING SYSTEMS



HYDRAULIC  
OIL COOLING

## ADVANTAGES



STAINLESS BRAZING  
ALLOWS HOMOGENEOUS  
CONSTRUCTION



HIGH SANITARY  
STANDARDS



RESISTANCE  
TO HIGH TEMPERATURE  
AND PRESSURE



RESISTANCE  
TO CORROSION



HIGH  
DURABILITY



WIDE RANGE  
OF APPLICATIONS



NO COPPER IONS  
IN THE WATER

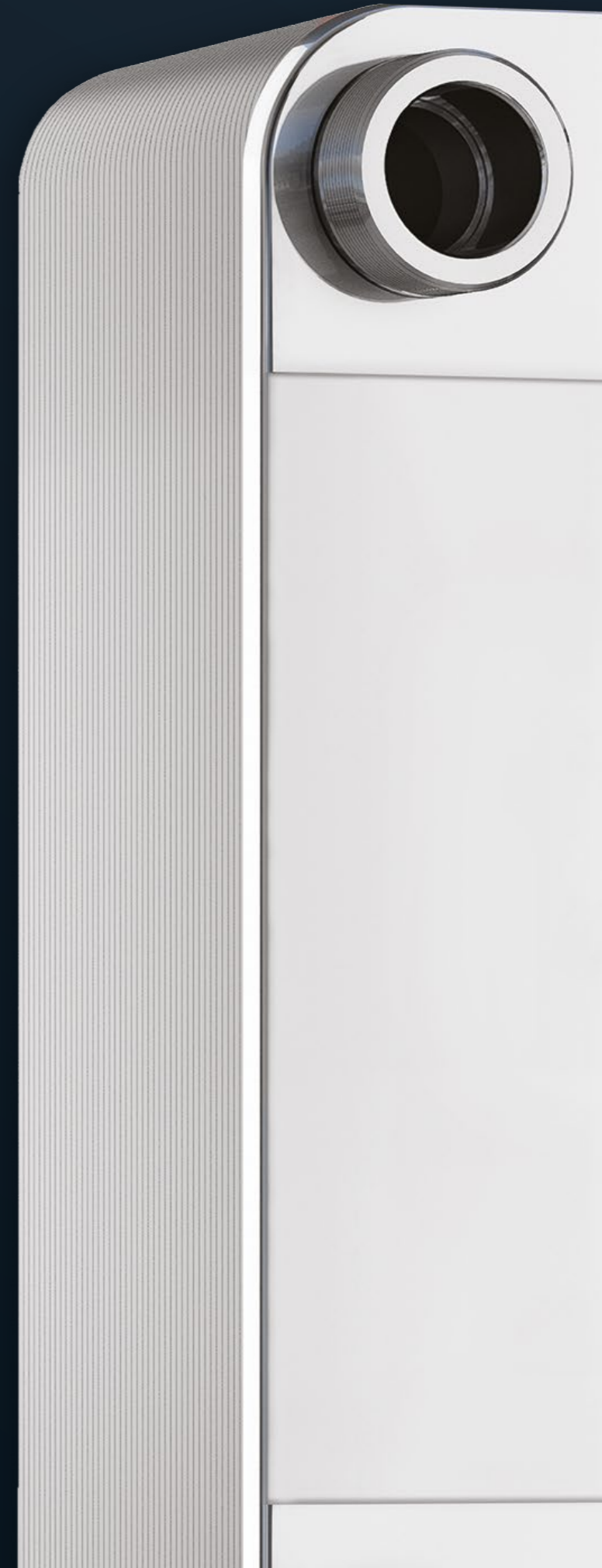



EXEMPLAR DESIGNATION

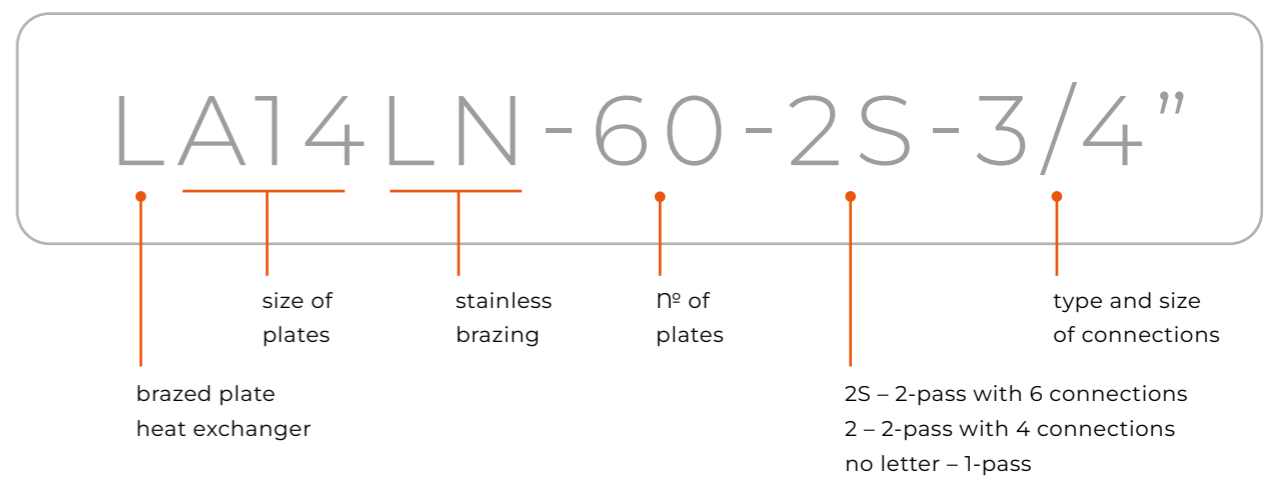

PRODUCT LINE



# TECHNICAL DATA

## STANDARD LOCATION OF CONNECTIONS

### 1-PASS HEAT EXCHANGER

- K1 / K4** — inlet / outlet hot side
- K3 / K2** — inlet / outlet cold side

### 2-PASS HEAT EXCHANGER

- D4 / K4** — inlet / outlet hot side
- K3 / D3** — inlet / outlet cold side

### 2-PASS WITH 6 CONNECTIONS

#### ADDITIONALLY:

- K1** — vent connection / inlet of central heating return
- K2** — vent connection / inlet of domestic hot water circulation return

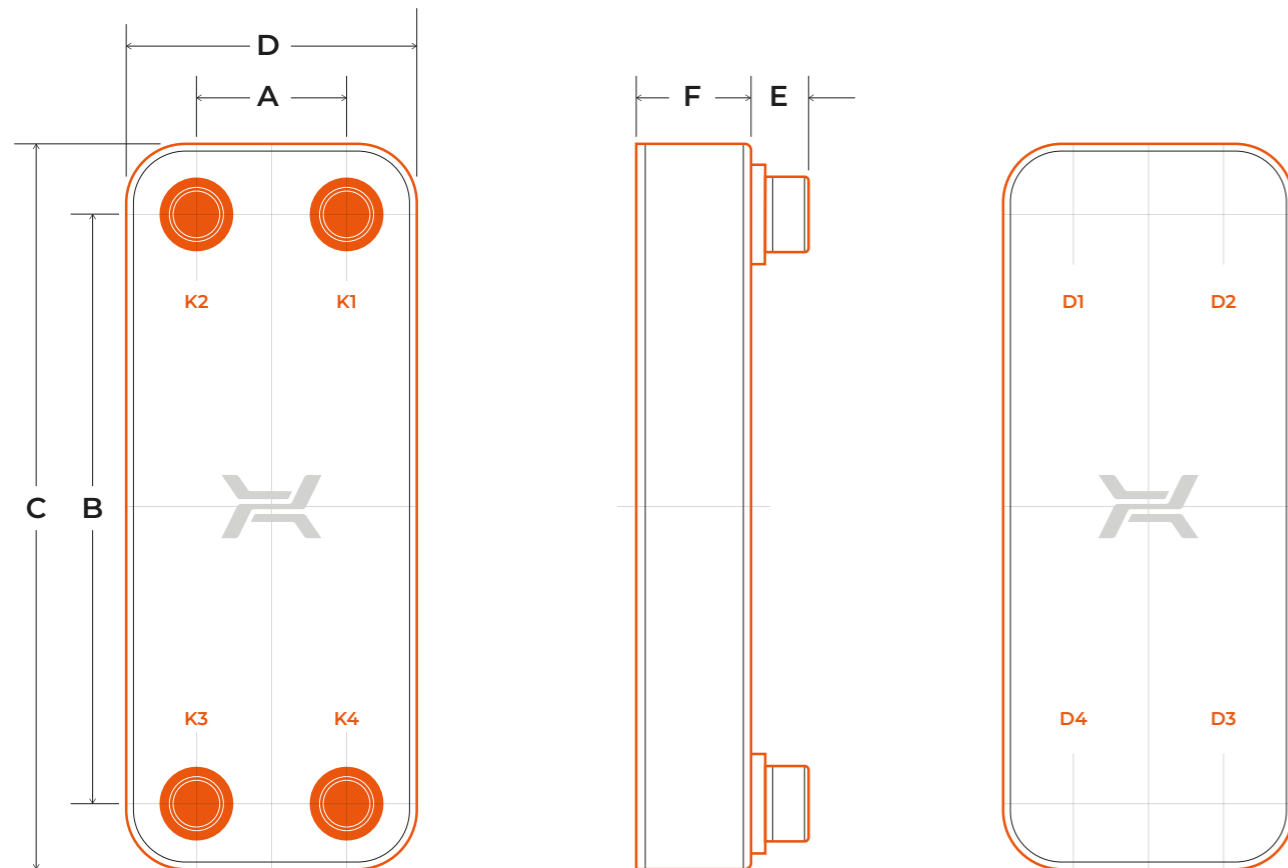

### MATERIALS

- STAINLESS STEEL
- STAINLESS BRAZING

### EXEMPLARY MEDIA

- WATER
- PROPYLENE
- GROUP II FLUIDS
- OTHER (CONSULT THE MANUFACTURER)

### WORKING PARAMETERS

- MAX. TEMPERATURE — 200°C
- MIN. TEMPERATURE — -195°C

#### MAX. PRESSURE

- LA LN, LB LN — 2 MPA
- LC LN, LD LN — 1,6 MPA
- LM LN — 2,5 MPA

# TECHNICAL PARAMETERS

Type	Dimensions												max. n° of plates	Mass	
	A		B		C		D		E		F			kg	lb
	mm	in	mm	in	mm	in	mm	in	mm	in	mm	in			
LA14LN	42	1.7	164	6.5	203	8.0	81	3.2	16	0.6	9 + 2,3 × NP	0.35 + 0.09 × NP	60	0,6 + 0,054 × NP	1.32 + 0.12 × NP
LA22LN	42	1.7	260	10.2	299	11.8	81	3.2	16	0.6	9 + 2,3 × NP	0.35 + 0.09 × NP	60	0,8 + 0,075 × NP	1.76 + 0.17 × NP
LA34LN	42	1.7	432	17.0	471	18.5	81	3.2	16	0.6	9 + 2,3 × NP	0.35 + 0.09 × NP	60	1,2 + 0,112 × NP	2.65 + 0.25 × NP
LB31LN	68	2.7	232	9.1	286	11.3	123	4.8	28	1.1	10 + 2,35 × NP	0.39 + 0.09 × NP	150	1,6 + 0,126 × NP	3.53 + 0.28 × NP
LB47LN	68	2.7	360	14.2	417	16.4	123	4.8	28	1.1	10 + 2,35 × NP	0.39 + 0.09 × NP	150	2,2 + 0,174 × NP	4.85 + 0.38 × NP
LB60LN	68	2.7	480	18.9	538	21.2	123	4.8	28	1.1	10 + 2,35 × NP	0.39 + 0.09 × NP	150	2,7 + 0,219 × NP	5.95 + 0.48 × NP
LM110LN	91	3.6	520	20.5	619	24.4	190	7.5	48	1.9	10 + 2,6 × NP	0.39 + 0.10 × NP	180	14,68 + 0,864 × NP	6.66 + 0.392 × NP
LC110LN	170	6.7	378	14.9	466	18.4	258	10.2	28;100	1.1; 3.9	11 + 2,4 × NP	0.43 + 0.09 × NP	180	9,1 + 0,454 × NP	20.06 + 0.99 × NP
LC170LN	170	6.7	600	23.6	688	27.1	258	10.2	28;100	1.1; 3.9	11 + 2,4 × NP	0.43 + 0.09 × NP	180	11,9 + 0,642 × NP	26.24 + 1.41 × NP
LD235LN	204	8.0	682	26.9	788	31.0	310	12.2	100	3.9	13 + 2,5 × NP	0.51 + 0.1 × NP	160	40,8 + 0,049 × NP	89.95 + 0.11 × NP

NP – number of plates | dim. F+/-3%

All dimensions and technical data are approximate only and may be changed without further notice.



# R

## BRAZED PLATE HEAT EXCHANGERS

DESIGNED FOR USE IN COOLING OR HEATING INSTALLATIONS. REFRIGERANT EVAPORATORS, CONDENSERS AND ECONOMIZERS.

### APPLICATION



CHILLERS



REFRIGERATION UNITS



HEAT PUMPS



ICE WATER GENERATORS



COOLING SYSTEMS WITH SPECIAL CONSTRUCTION

### ADVANTAGES



OUTSTANDING RELIABILITY



OPTIMIZED FOR MODERN REFRIGERANTS



RESISTANCE TO CYCLIC FATIGUE



SPECIAL CHANNEL PATTERN ENSURES EFFECTIVE EVAPORATION OR CONDENSATION



RESISTANCE TO FREEZING



### EVAPORATORS

A two-phase refrigerant is sent to the bottom welded connection of the exchanger. Flowing through the channels it evaporates completely while acquiring the required degree of overheating. Water or glycol flows in counter-current flow.

### CONDENSERS

Hot refrigerant vapours are sent to the top welded connection of the exchanger. Flowing through the channels they condense while acquiring the required degree of subcooling. Water and glycol flows in counter-current flow.

### RDS SYSTEM

Hexonic developed the unique refrigerant distribution system RDS, for evaporators with potentially higher cooling performance.

The system ensures even medium distribution in evaporator channels, while at the same time reducing steam overheating fluctuations.

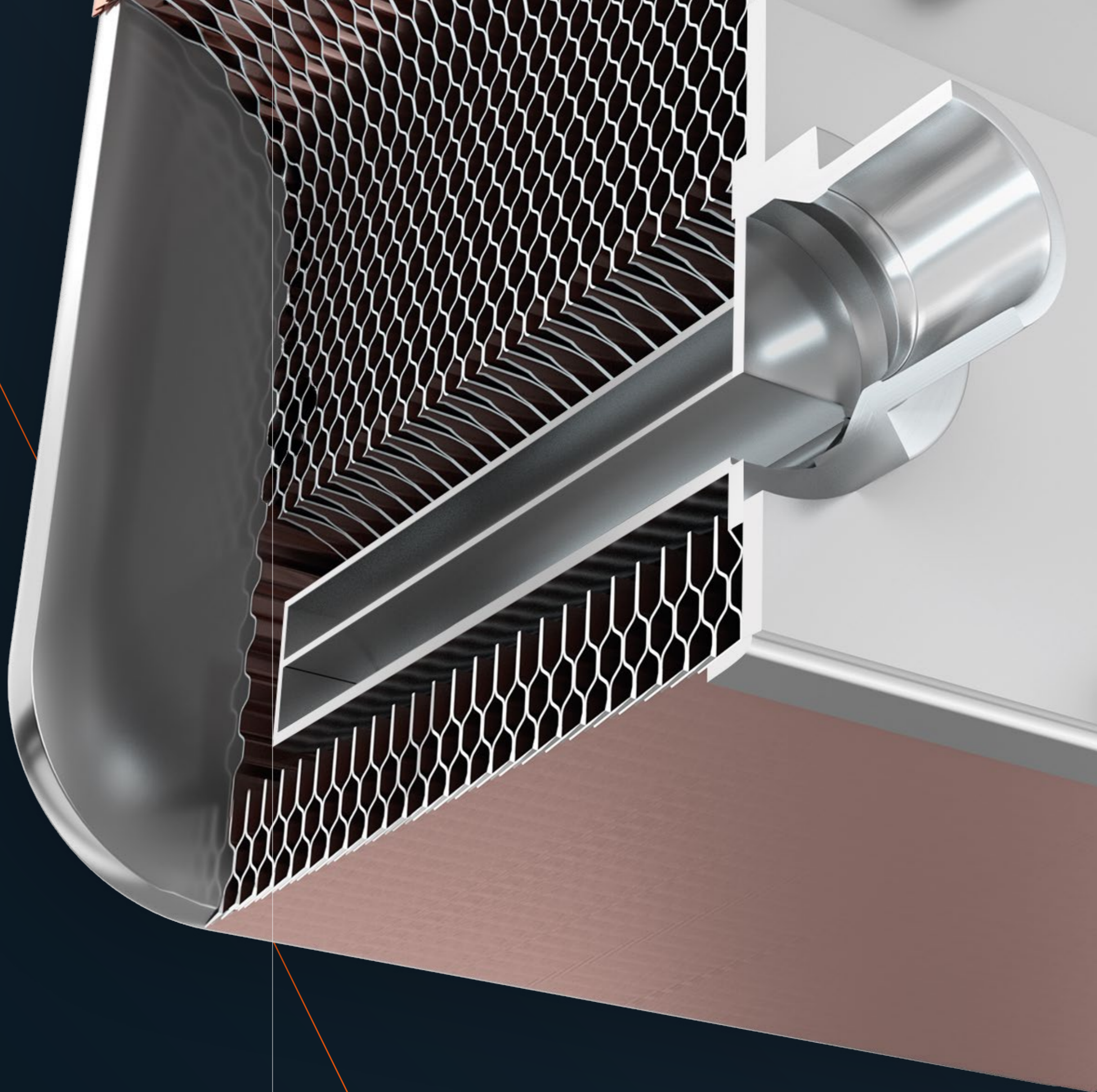



EXEMPLAR DESIGNATION

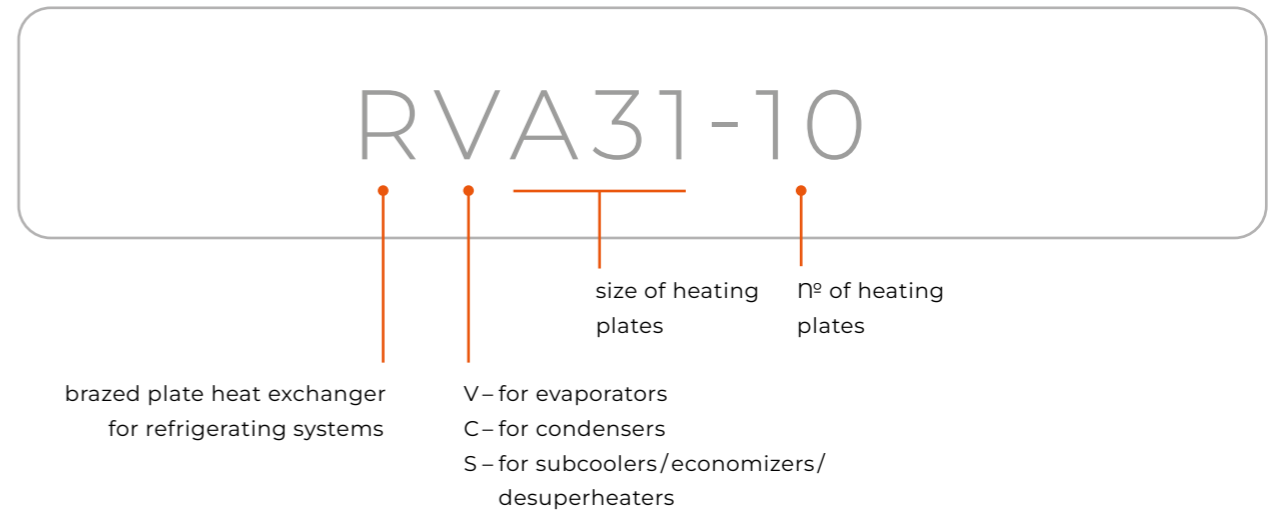

PRODUCT LINE



# TECHNICAL DATA

## STANDARD LOCATION OF CONNECTIONS

(DEPENDING ON WHETHER IT IS EVAPORATOR OR CONDENSER)

- K 4 / K 1** — inlet /outlet of refrigerant
- K 3 / K 2** — inlet /outlet of water or glycol

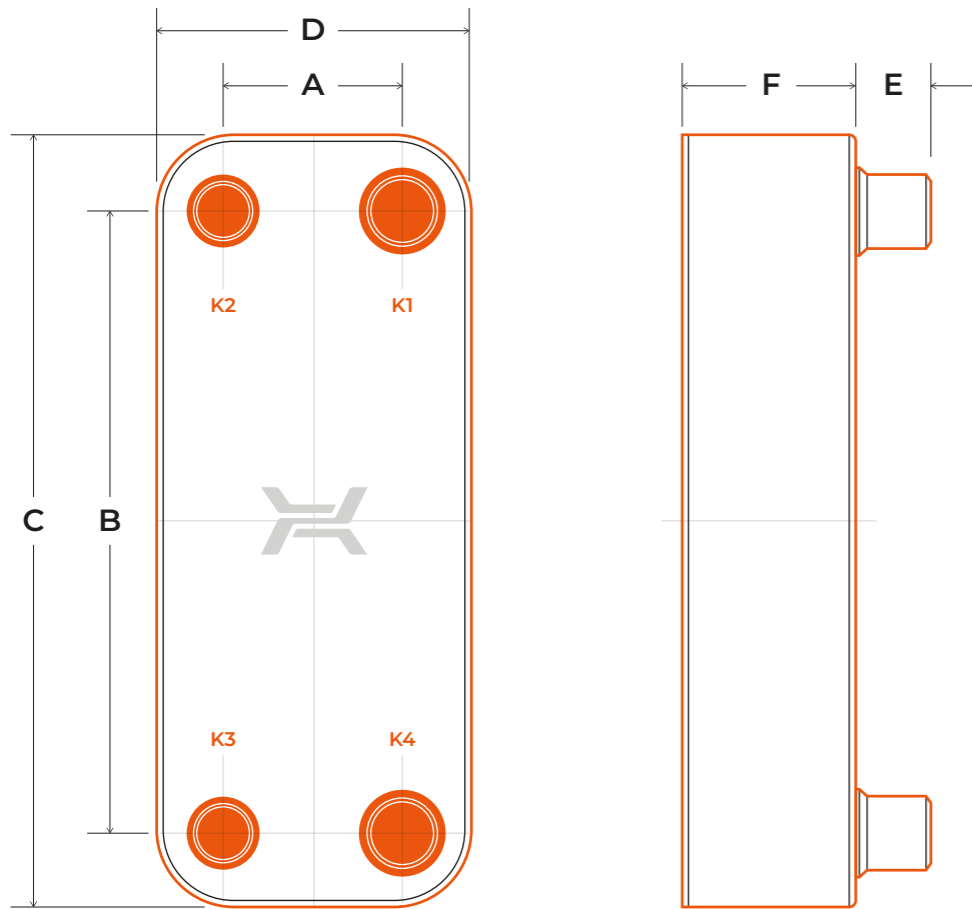

### MATERIALS

- STAINLESS STEEL
- COPPER BRAZING

### EXEMPLARY MEDIA

#### REFRIGERANT SIDE

- R32, R452B, R454B, R1234ZE, R290, R410

#### OTHER SIDE

- WATER
- PROPYLENE GLYCOL SOLUTIONS
- GROUP II FLUIDS
- OTHER (CONSULT THE MANUFACTURER)

### WORKING PARAMETERS

MAX. TEMPERATURE — 150°C / 302°F

MIN. TEMPERATURE — -195°C / -319°F

#### MAX. PRESSURE

REFRIGERANT SIDE — 4,5 MPA / 653 PSI  
 WATER, GLYCOL SIDE — 2,5 MPA / 363 PSI

# TECHNICAL PARAMETERS

Type	Dimensions										Weight			
	A		B		C		D		E		F		kg	lb
	mm	in	mm	in	mm	in	mm	in	mm	in	mm	in	kg	lb

### EVAPORATORS

<b>RVA14</b>	42	1,7	164	6,5	203	8,0	81	3,2	16	0,6	9 + 2,3 × NP	0,35 + 0,09 × NP	0,7 + 0,049 × NP	1,54 + 0,11 × NP
<b>RVA22</b>	42	1,7	260	10,2	299	11,8	81	3,2	16	0,6	9 + 2,3 × NP	0,35 + 0,09 × NP	0,9 + 0,073 × NP	1,98 + 0,16 × NP
<b>RVA34</b>	42	1,7	432	17,0	471	18,5	81	3,2	16	0,6	9 + 2,3 × NP	0,35 + 0,09 × NP	1,3 + 0,116 × NP	2,87 + 0,26 × NP
<b>RVB31</b>	68	2,7	232	9,1	286	11,3	123	4,8	28	1,1	10 + 2,35 × NP	0,39 + 0,09 × NP	1,7 + 0,114 × NP	3,75 + 0,25 × NP
<b>RVB47</b>	68	2,7	360	14,2	417	16,4	123	4,8	28	1,1	10 + 2,35 × NP	0,39 + 0,09 × NP	2,3 + 0,168 × NP	5,07 + 0,37 × NP
<b>RVB60</b>	68	2,7	480	18,9	538	21,2	123	4,8	28	1,1	10 + 2,35 × NP	0,39 + 0,09 × NP	2,8 + 0,219 × NP	6,17 + 0,48 × NP
<b>RVB60X</b>	68	2,7	480	18,9	538	21,2	123	4,8	28	1,1	13 + 1,95 × NP	0,39 + 0,077 × NP	2,8 + 0,219 × NP	6,17 + 0,48 × NP
<b>RVC110</b>	170	6,7	378	14,9	466	18,3	258	10,2	28	1,1	10 + 2,4 × NP	0,39 + 0,09 × NP	8,8 + 0,409 × NP	19,40 + 0,9 × NP
<b>RVC170</b>	170	6,7	600	23,6	688	27,1	258	10,2	28	1,1	10 + 2,4 × NP	0,39 + 0,09 × NP	11,5 + 0,617 × NP	25,35 + 1,36 × NP
<b>RVM110</b>	91	3,6	520	20,5	619	24,4	190	7,5	28	1,1	10 + 2,6 × NP	0,393 + 0,102 × NP	8,4 + 0,408 × NP	18,52 + 0,9 × NP
<b>RVD235</b>	204	8,0	682	26,9	788	31,0	310	12,2	28	1,1	13 + 2,5 × NP	0,51 + 0,10 × NP	40 + 0,828 × NP	88,18 + 1,83 × NP

### CONDENSERS

<b>RCA14</b>	42	1,7	164	6,5	203	8,0	81	3,2	16	0,6	9 + 2,3 × NP	0,35 + 0,09 × NP	0,7 + 0,049 × NP	1,54 + 0,11 × NP
<b>RCA22</b>	42	1,7	260	10,2	299	11,8	81	3,2	16	0,6	9 + 2,3 × NP	0,35 + 0,09 × NP	0,9 + 0,073 × NP	1,98 + 0,16 × NP
<b>RCA34</b>	42	1,7	432	17,0	471	18,5	81	3,2	16	0,6	9 + 2,3 × NP	0,35 + 0,09 × NP	1,3 + 0,116 × NP	2,87 + 0,26 × NP
<b>RCB31</b>	68	2,7	232	9,1	286	11,3	123	4,8	28	1,1	10 + 2,35 × NP	0,35 + 0,09 × NP	1,7 + 0,114 × NP	3,75 + 0,25 × NP
<b>RCB47</b>	68	2,7	360	14,2	417	16,4	123	4,8	28	1,1	10 + 2,35 × NP	0,39 + 0,09 × NP	2,3 + 0,168 × NP	5,07 + 0,37 × NP
<b>RCB60</b>	68	2,7	480	18,9	538	21,2	123	4,8	28	1,1	10 + 2,35 × NP	0,39 + 0,09 × NP	2,8 + 0,219 × NP	6,17 + 0,48 × NP
<b>RCB60X</b>	68	2,7	480	18,9	538	21,2	123	4,8	28	1,1	13 + 1,95 × NP	0,39 + 0,077 × NP	2,8 + 0,219 × NP	6,17 + 0,48 × NP
<b>RCC110</b>	170	6,7	378	14,9	466	18,3	258	10,2	28	1,1	10 + 2,4 × NP	0,39 + 0,09 × NP	8,8 + 0,409 × NP	19,4 + 0,9 × NP
<b>RCC170</b>	170	6,7	600	23,6	688	27,1	258	10,2	28	1,1	10 + 2,4 × NP	0,39 + 0,09 × NP	11,5 + 0,617 × NP	25,35 + 1,36 × NP
<b>RCM110</b>	91	3,6	520	20,5	619	24,4	190	7,5	28	1,1	10 + 2,6 × NP	0,39 + 0,10 × NP	8,4 + 0,408 × NP	18,52 + 0,9 × NP
<b>RCD235</b>	204	8,0	682	26,9	788	31,0	310	12,2	28	1,1	13 + 2,5 × NP	0,51 + 0,10 × NP	40 + 0,828 × NP	88,18 + 1,83 × NP

### SUBCOOLERS / ECONOMIZERS / DESUPERHEATERS

<b>RSA14</b>	42	1,7	164	6,5	203	8,0	81	3,2	16	0,6	9 + 2,3 × NP	0,35 + 0,09 × NP	0,7 + 0,049 × NP	1,54 + 0,11 × NP
<b>RSA22</b>	42	1,7	260	10,2	299	11,8	81	3,2	16	0,6	9 + 2,3 × NP	0,35 + 0,09 × NP	0,9 + 0,073 × NP	1,98 + 0,16 × NP
<b>RSA34</b>	42	1,7	432	17,0	471	18,5	81	3,2	16	0,6	9 + 2,3 × NP	0,35 + 0,09 × NP	1,3 + 0,116 × NP	2,87 + 0,26 × NP
<b>RSB31</b>	68	2,7	232	9,1	286	11,3	123	4,8	28	1,1	10 + 2,35 × NP	0,39 + 0,09 × NP	1,7 + 0,114 × NP	3,75 + 0,25 × NP
<b>RSB47</b>	68	2,7	360	14,2	417	16,4	123	4,8	28	1,1	10 + 2,35 × NP	0,39 + 0,09 × NP	2,3 + 0,168 × NP	5,07 + 0,37 × NP

NP - number of plates | dim. F±3%

All dimensions and technical data are approximate only and may be changed without further notice.

COOLING CAPACITY TABLE FOR LOW POWER INSTALLATIONS

EVAPORATOR [dT <sub>GROUND SOURCE</sub> =5K]						CONDENSER [dT <sub>INSTALLATION</sub> =10K]							
W12	R32	R452B	R454B	R1234ZE	R290	R410	W35	R32	R452B	R454B	R1234ZE	R290	R410
4 kW	RVA22-60	RVA22-50	RVA22-50	RVB31H-40	RVA22-50	RVA22-50	4 kW	RCA14-40	RCA14-40	RCA14-40	RCA14-40	RCA14-50	RCA14-30
6 kW	RVA34-30	RVA34-20	RVA34-20	RVB31H-50	RVA34-20	RVA34-20	6 kW	RCA14-50	RCA14-60	RCA14-60	RCA14-60	RCA22-40	RCA14-50
9 kW	RVA34-30	RVA34-30	RVA34-30	RVC110-30	RVB31H-80	RVA34-30	9 kW	RCA22-40	RCA22-50	RCA22-50	RCA22-40	RCA22-50	RCA14-60
12 kW	RVB47H-50	RVB47H-40	RVB47H-40	RVC110-40	RVB47H-50	RVB47H-50	12 kW	RCA22-50	RCA22-60	RCA22-60	RCA22-60	RCA22-60	RCA22-50
16 kW	RVB47H-90	RVB47H-70	RVB47H-70	RVC110-50	RVC110-40	RVB47H-70	16 kW	RCA22-60	RCA34-40	RCA34-40	RCB31-80	RCA34-30	RCA22-60
20 kW	RVB60H-40	RVB60H-40	RVB60H-40	RVC110-70	RVC110-50	RVB60H-40	20 kW	RCA34-30	RCA34-40	RCA34-40	RCB31-90	RCA34-40	RCA34-50
25 kW	RVC110-80	RVC110-70	RVC110-70	RVC110-100	RVC110-70	RVC110-70	25 kW	RCA34-40	RCA34-50	RCA34-50	RCB31H-80	RCB31H-90	RCA34-60
35 kW	RVC170-40	RVC170-30	RVC170-30	RVD235-30	RVC170-30	RVC170-30	35 kW	RCA34-50	RCB47-80	RCB47-80	RC110-40	RCB47-90	RCB31H-100
50 kW	RVC170-50	RVC170-40	RVC170-40	—	RVD235-30	RVC170-50	50 kW	RCB47-90	RCB47H-100	RCB47H-100	RC110-50	RC110-60	RCB47-100
60 kW	RVC170-60	RVC170-50	RVC170-50	—	RVD235-40	RVC170-50	60 kW	RCB47H-90	RCB60-90	RCB60-90	RC110-60	RC110-70	RCB60-80
W7	R32	R452B	R454B	R1234ZE	R290	R410	W45	R32	R452B	R454B	R1234ZE	R290	R410
4 kW	RVA34-20	RVA22-50	RVA22-50	RVB31H-40	RVA22-60	RVA22-50	4 kW	RCA14-40	RCA14-50	RCA14-50	RCA14-50	RCA14-50	RCA14-50
6 kW	RVA34-30	RVA34-20	RVA34-20	RVB31H-60	RVB31H-50	RVA34-30	6 kW	RCA14-50	RCA14-60	RCA14-60	RCA22-30	RCA22-40	RCA22-40
9 kW	RVA34-40	RVB31H-90	RVB31H-90	RVC110-30	RVB31H-90	RVA34-40	9 kW	RCA22-40	RCA22-50	RCA22-50	RCA22-50	RCA22-50	RCA22-50
12 kW	RVB47H-60	RVB47H-50	RVB47H-50	RVC110-40	RVC110-30	RVB47H-50	12 kW	RCA22-50	RCA22-60	RCA22-60	RCA22-60	RCA22-60	RCA22-60
16 kW	RVB60-80	RVB47H-80	RVB47H-80	RVC110-50	RVC110-40	RVB47H-90	16 kW	RCA22-60	RCA34-40	RCA34-40	RCA34-30	RCA34-30	RCA34-40
20 kW	RVB60H-50	RVB60H-40	RVB60H-40	RVC110-70	RVC110-60	RVB60H-50	20 kW	RCA34-30	RCA34-50	RCA34-50	RCB31-100	RCA34-40	RCA34-40
25 kW	RVC110-90	RVC110-70	RVC110-80	RVD235-30	RVC110-80	RVC110-80	25 kW	RCA34-40	RCA34-60	RCA34-60	RCB31H-90	RCA34-50	RCA34-50
35 kW	RVC170-40	RVC170-30	RVC170-30	RVD235-40	RVC170-40	RVC170-40	35 kW	RCA34-50	RCB47-90	RCB47-90	RCB47-80	RCB47-90	RCB47-90
50 kW	RVC170-50	RVC170-50	RVC170-40	—	RVD235-40	RVC170-50	50 kW	RCB47-90	RCB60-80	RCB60-80	RC110-60	RCB60-80	RCB60-80
60 kW	RVC170-60	RVC170-50	RVC170-50	—	RVD235-40	RVC170-60	60 kW	RCB47H-100	RCB60-100	RCB60-100	RC110-60	RC110-70	RCB60-100
B0	R32	R452B	R454B	R1234ZE	R290	R410	W55	R32	R452B	R454B	R1234ZE	R290	R410
4 kW	RVA34-30	RVA34-30	RVA34-30	RVB47H-50	RVA34-30	RVA34-30	4 kW	RCA14-40	RCA14-40	RCA14-50	RCA14-50	RCA14-50	RCA14-50
6 kW	RVA34-40	RVA34-30	RVA34-30	RVC110-40	RVB47H-60	RVA34-40	6 kW	RCA14-60	RCA14-60	RCA22-40	RCA22-30	RCA22-40	RCA22-40
9 kW	RVB60-60	RVB60-40	RVB60-40	RVC110-50	RVB60H-40	RVB60H-40	9 kW	RCA22-40	RCA22-50	RCA22-50	RCA22-50	RCA22-50	RCA22-50
12 kW	RVB60H-50	RVB60H-40	RVB60H-40	RVC170-30	RVC110-60	RVB60H-50	12 kW	RCA22-50	RCA22-60	RCA34-30	RCA22-60	RCA34-30	RCA34-30
16 kW	RVB60H-70	RVB60H-60	RVB60H-60	RVC170-30	RVC170-30	RVC170-30	16 kW	RCA22-60	RCA34-40	RCA34-40	RCA34-30	RCA34-30	RCA34-30
20 kW	RVC170-30	RVC170-30	RVC170-30	RVD235-30	RVC170-30	RVC170-30	20 kW	RCA34-30	RCA34-50	RCA34-50	RCB31-100	RCA34-40	RCA34-40
25 kW	RVC170-40	RVC170-40	RVC170-40	RVD235-40	RVC170-40	RVC170-40	25 kW	RCA34-40	RCA34-60	RCA34-60	RCB31H-90	RCA34-50	RCA34-50
35 kW	RVC170-50	RVC170-50	RVC170-50	—	RVD235-40	RVC170-50	35 kW	RCA34-50	RCB47-90	RCB47-90	RCB47-80	RCB47-90	RCA34-60
50 kW	RVC170-70	RVC170-60	RVC170-60	—	RVD235-50	RVD235-50	50 kW	RCB47-100	RCB60-80	RCB60-90	RC110-60	RCB60-80	RCB60-80
60 kW	RVD235-60	RVD235-50	RVD235-50	—	—	RVD235-60	60 kW	RCB47H-90	RCB60-100	RCB60-100	RC110-70	RCB60-90	RCB60-90

EVAPORATOR

MEDIUM  
EVAPORATION TEMP.  
— 4/-1/-8°C  
OVERHEATING — 3K

WATER  
12/7°C – 7/2°C  
DPMAX < 30KPA

PG35  
0/-5°C  
DPMAX < 30KPA

CONDENSER

MEDIUM  
CONDENSING TEMP.  
— 58/48/38°C  
OVERCOOLING — 2K

WATER  
23/35°C – 35/45°C – 45/55°C  
DPMAX < 30KPA

ECONOMIZER

	R410A
4 kW	RSA14-10
6 kW	RSA14-10
9 kW	RSA14-20
12 kW	RSA14-30
16 kW	RSB31-15
20 kW	RSB31-20
25 kW	RSB31-20
35 kW	RSB31-30
50 kW	RSB31-40
60 kW	RSB31-60

COOLING CAPACITY TABLE FOR HIGH POWER INSTALLATIONS

EVAPORATOR [dT <sub>GROUND SOURCE</sub> =10K]			CONDENSER [dT <sub>INSTALLATION</sub> =5K]				
power [kW]	R1234ZE E	R134A	R290	power [kW]	R1234ZE E	R134A	R290
	W50W90 dT=10K	W45W80 dT=10K	W35W70 dT=10K		W50W90 dT=10K	W45W80 dT=10K	W35W70 dT=10K
150 kW	RVC170-60	RVC170-60	RVC170-60	150 kW	RCC110-80	RCC110-70	RCC110-50
180 kW	RVC170-70	RVC170-70	RVC170-70	180 kW	RCC110-90	RCC110-80	RCC110-60
210 kW	RVC170-80	RVC170-80	RVC170-80	210 kW	RCC110-100	RCC110-90	RCC110-70
240 kW	RVD235-70	RVD235-70	RVC170-90	240 kW	RCC170-70	RCC170-80	RCC170-80
270 kW	RVD235-80	RVD235-80	RVD235-80	270 kW	RCC170-90	RCC170-90	RCC170-90
300 kW	RVD235-90	RVD235-90	RVD235-90	300 kW	RCC170-100	RCC170-100	RCC170-100
350 kW	RVD235-100	RVD235-100	RVD235-100	350 kW	RCC170-120	RCC170-120	RCC170-120
400 kW	RVD235-120	RVD235-120	RVD235-120	400 kW	RCD235-100	RCD235-100	RCD235-100
450 kW	RVD235-130	RVD235-110	RVD235-110	450 kW	RCD235-110	RCD235-110	RCD235-110
500 kW	RVD235-140	RVD235-120	RVD235-130	500 kW	RCD235-120	RCD235-120	RCD235-120
power [kW]	R1234ZE E	R134A	R290	power [kW]	R1234ZE E	R134A	R290
	W50W90 dT=5K	W45W80 dT=5K	W35W70 dT=5K		W50W90 dT=5K	BW	W35W70 dT=5K
150 kW	RVD235-50	RVC170-70	RVC170-60	150 kW	RCC170-70	RCC170-70	RCC170-50
180 kW	RVD235-60	RVD235-50	RVD235-50	180 kW	RCC170-90	RCC170-80	RCC170-60
210 kW	RVD235-70	RVD235-60	RVD235-60	210 kW	RCC170-100	RCC170-100	RCC170-70
240 kW	RVD235-80	RVD235-70	RVD235-70	240 kW	RCC170-110	RCC170-110	RCC170-80
270 kW	RVD235-90	RVD235-80	RVD235-80	270 kW	RCC170-130	RCC170-120	RCC170-90
300 kW	—	—	RVD235-90	300 kW	RCC170-140	RCC170-130	RCC170-100
350 kW	—	—	RVD235-100	350 kW	RCD235-110	RCC170-150	RCC170-120
400 kW	—	—	RVD235-110	400 kW	RCD235-130	RCD235-120	RCD235-100
450 kW	—	—	—	450 kW	RCD235-140	RCD235-130	RCD235-110
500 kW	—	—	—	500 kW	RCD235-150	RCD235-150	RCD235-120

EVAPORATOR

MEDIUM  
EVAPORATION TEMP.  
— 35/30/25°C  
OVERHEATING — 3K

WATER  
50/45°C – 45/40°C – 35/30°C  
DPMAX < 30KPA

MEDIUM  
EVAPORATION TEMP.  
— 45/35/30°C  
OVERHEATING — 3K

WATER  
50/45°C – 45/40°C – 35/30°C  
DPMAX < 30KPA

CONDENSER

MEDIUM  
CONDENSING TEMP.  
— 100/90/80°C  
OVERCOOLING — 2K

WATER  
80/90°C – 70/80°C – 60/70°C  
DPMAX < 30KPA

WATER  
85/95°C – 75/85°C – 65/75°C  
DPMAX < 30KPA

## THE HIGH-PERFORMANCE PLATE

Our product range of brazed plate heat exchangers stands out for its extensive assortment and adaptable features, offering unmatched diversity in size, brazing material, connection types, flow arrangements, and accessory options. Now, we have gone one step further and created a reinforced heat exchanger dedicated to cooling and heating solutions. These ultra-efficient heat exchangers feature special heating plates "X", providing enhanced heat transfer efficiency and increased turbulence flow of the medium. Consequently, this leads to increased thermal efficiency, lower investment costs, and a reduced footprint.

### EXEMPLAR DESIGNATION

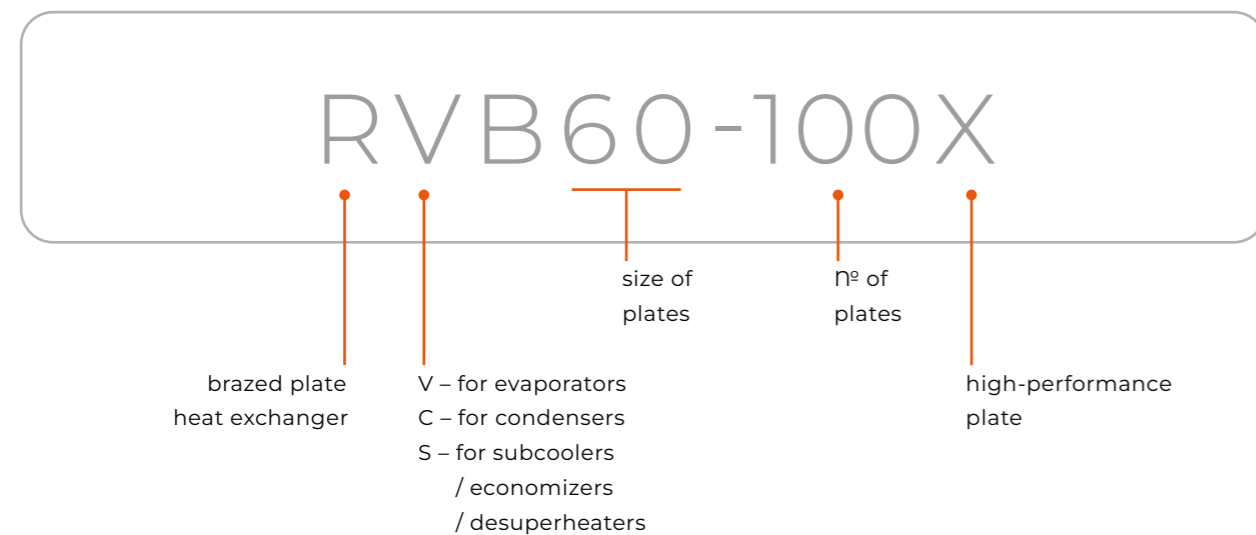
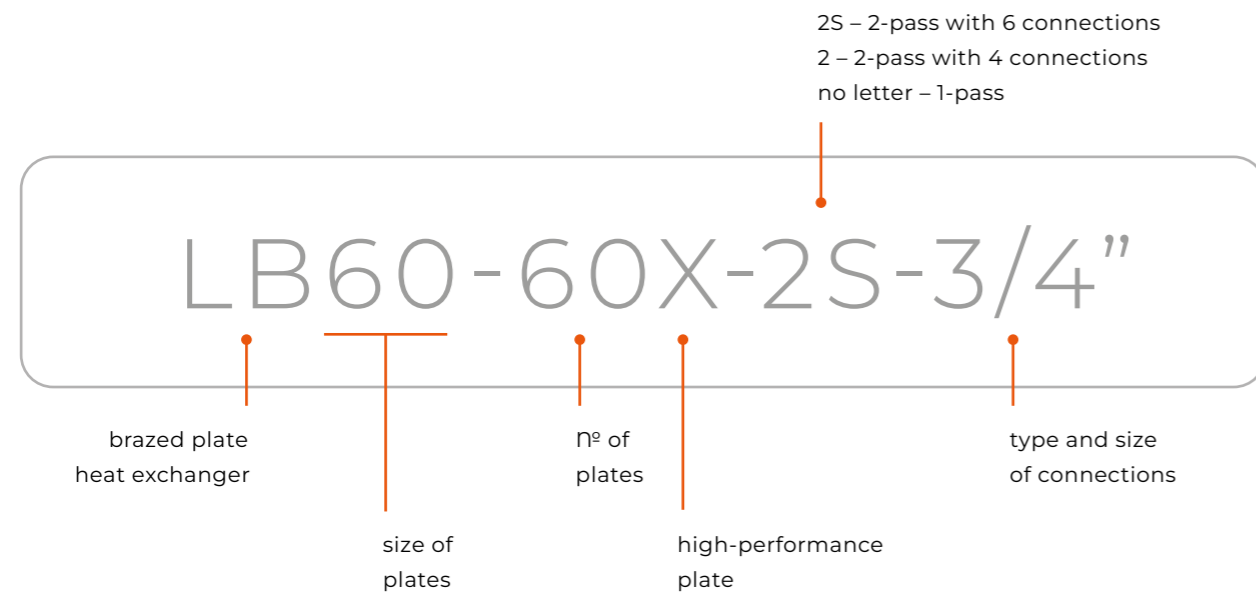

### ADVANTAGES



ULTRA-EFFICIENT HEAT EXCHANGER FOR HEATING AND COOLING



INCREASED FLOW TURBULENCE OF THE MEDIUM



OPTIMIZED FLUID FLOW



REDUCED REFRIGERANT USAGE



ENHANCED THERMAL EFFICIENCY

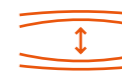

REINFORCED CONSTRUCTION FOR HIGHER PRESSURES



INCREASED HEAT EXCHANGE AREA



LOW CARBON FOOTPRINT

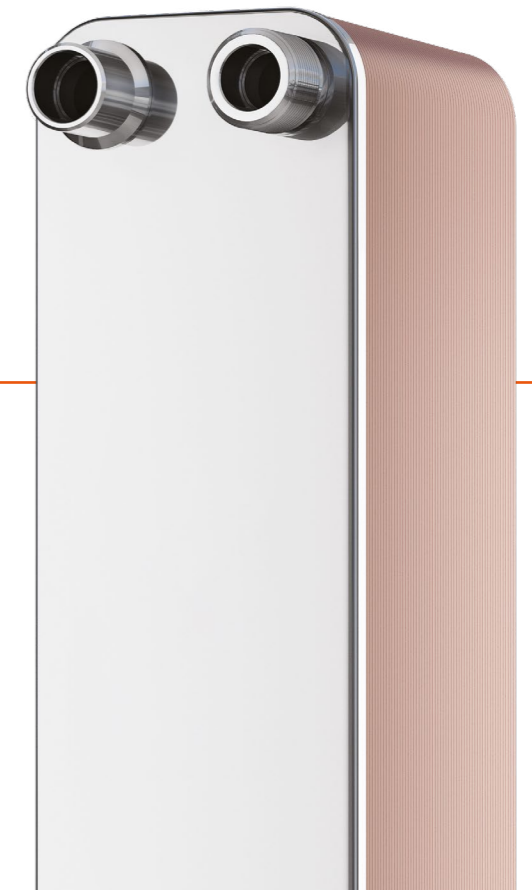

# SafePLATE

**DOUBLE WALL HEAT EXCHANGERS**  
DESIGNED FOR APPLICATIONS WHERE IT IS CRUCIAL TO DOUBLE-PROTECT MEDIA FROM MIXING AND QUICKLY DETECT ANY POTENTIAL INTERNAL LEAK.

## APPLICATION



TAP WATER HEATING SYSTEMS



CENTRAL HEATING SYSTEMS



TECHNOLOGICAL SYSTEMS

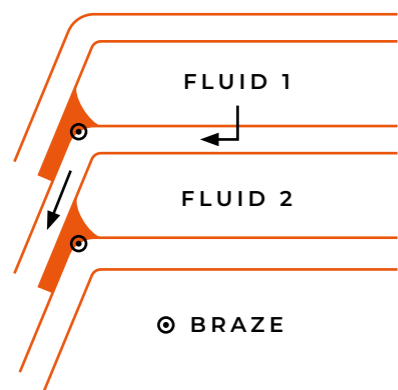

### DOUBLE-WALL SYSTEM

In case of failure, either corrosion or pressure induced, special arrangement of double walls and interspace in sidewalls helps to prevent potential mixing of working media and allows the leakage to be visually detected.

## ADVANTAGES



EFFECTIVE LEAK DETECTION



HELPS TO PREVENT POTENTIAL MIXING OF WORKING MEDIA



EXEMPLAR DESIGNATION

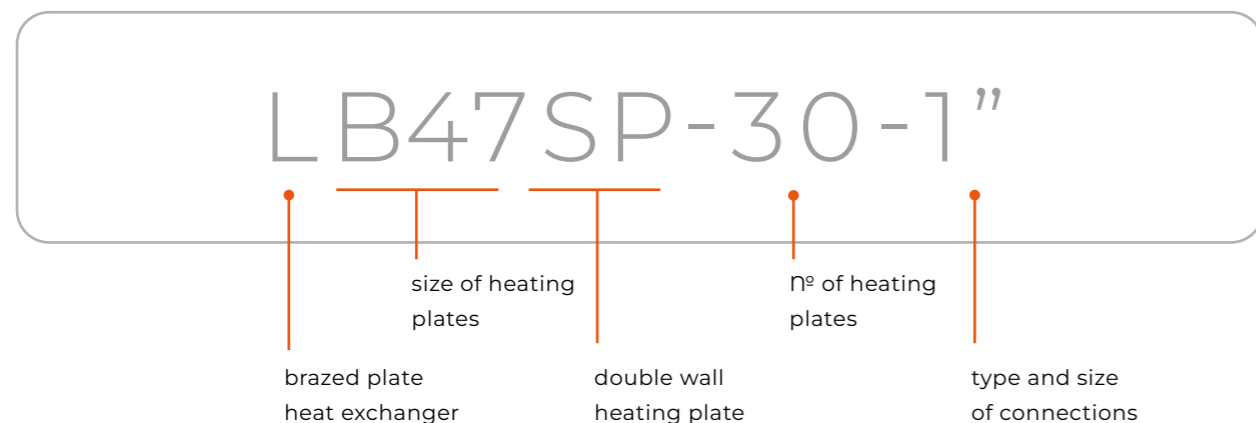

PRODUCT LINE

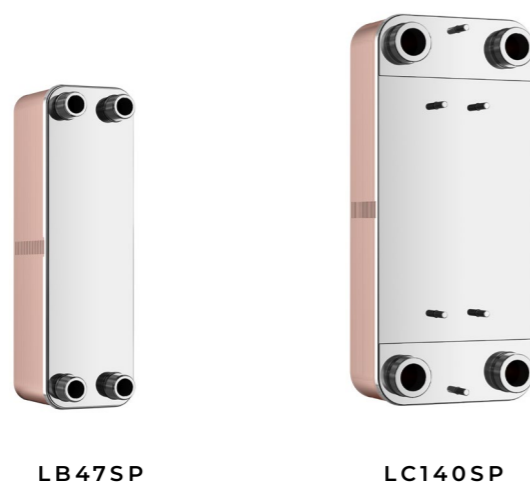

LB47SP

LC140SP

TECHNICAL DATA

MATERIALS

- STAINLESS STEEL
- COPPER BRAZING

EXEMPLARY MEDIA

- WATER
- PROPYLENE GLYCOL SOLUTIONS
- GROUP II FLUIDS
- OTHER (CONSULT THE MANUFACTURER)

WORKING PARAMETERS

MAX. TEMPERATURE — 230°C / 446°F

MIN. TEMPERATURE — -195°C / -319°F

MAX. PRESSURE

LA SP, LB SP — 3 MPA / 435 PSI

LC SP — 2 MPA / 290 PSI

STANDARD LOCATION OF CONNECTIONS

K1 / K4 — inlet / outlet hot side    K1 / K4 — inlet / outlet hot side

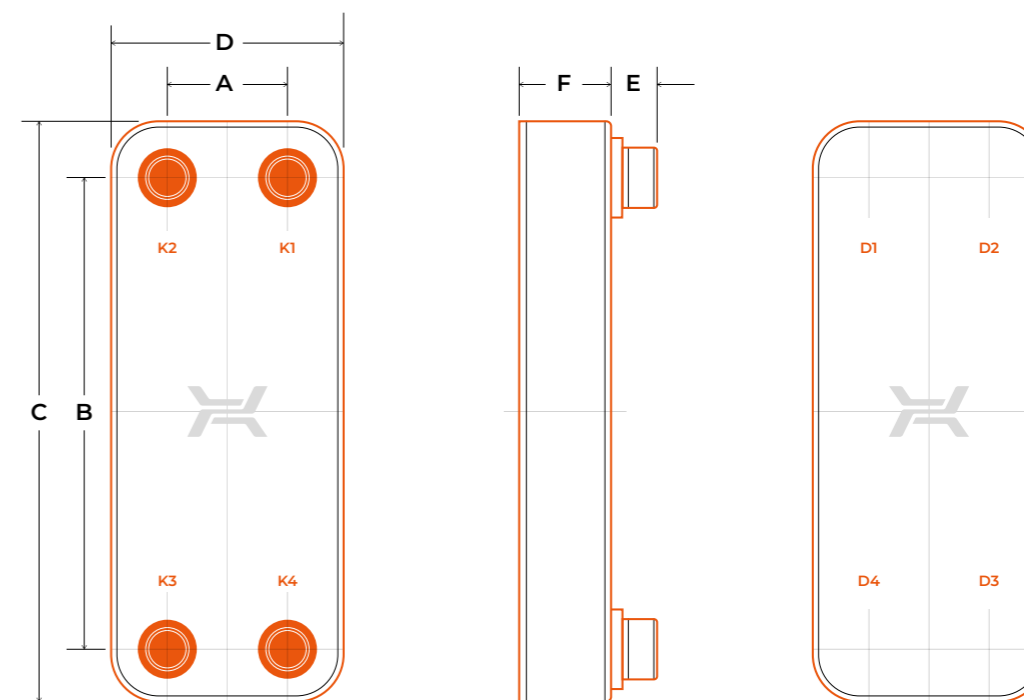

Double-wall heat exchangers have been designed to prevent media from mixing and enable quick leak detection. However, it should be remembered that no heat exchangers of this type guarantee the reliability of such operation and cannot be used instead of other safety systems.

TECHNICAL PARAMETERS

Type	Dimensions												max N° of pla- tes	Mass	
	A		B		C		D		E		F			kg	lb
	mm	in	mm	in	mm	in	mm	in	mm	in	mm	in			
LB47SP 1"	68	2,68	360	14,17	418	16,46	126	4,93	28	1,1	11 + 2,6 × NP	0,43 + 0,10 × NP	100	3,66 + 0,26 × NP	8,07 + 0,57 × NP
LB47SP ¾"	68	—	360	—	418	—	126	—	28	—	11 + 2,6 × NP	—	100	3,94 + 0,26 × NP	—
LC140SP L 2"	170	—	490	—	580	—	260	—	28	—	11 + 2,6 × NP	—	150	9,26 + 0,822 × NP	—
LC140SP M 2"	170	—	490	—	580	—	260	—	28	—	11 + 2,6 × NP	—	150	9,26 + 0,822 × NP	—
LC140SP H 2"	170	—	490	—	580	—	260	—	28	—	11 + 2,6 × NP	—	150	9,26 + 0,822 × NP	—
LC140SP L 2,5"	170	6,69	490	19,29	580	22,83	260	10,23	38	1,5	11 + 2,6 × NP	0,43 + 0,10 × NP	150	9,43 + 0,822 × NP	20,08 + 1,81 × NP
LC140SP M 2,5"	170	6,69	490	19,29	580	22,83	260	10,23	38	1,5	11 + 2,6 × NP	0,43 + 0,10 × NP	150	9,43 + 0,822 × NP	20,08 + 1,81 × NP
LC140SP H 2,5"	170	6,69	490	19,29	580	22,83	260	10,23	38	1,5	11 + 2,6 × NP	0,43 + 0,10 × NP	150	9,43 + 0,822 × NP	20,08 + 1,81 × NP
LC140SP L DN50	170	—	490	—	580	—	260	—	100	—	11 + 2,6 × NP	—	150	20,31 + 0,822 × NP	—
LC140SP M DN50	170	—	490	—	580	—	260	—	100	—	11 + 2,6 × NP	—	150	20,31 + 0,822 × NP	—
LC140SP H DN50	170	—	490	—	580	—	260	—	100	—	11 + 2,6 × NP	—	150	20,31 + 0,822 × NP	—
LC140SP	170	—	490	—	580	—	260	—	40	—	11 + 2,6 × NP	—	200	9,11 + 0,822 × NP	—

NP – number of plates | dim. F+/-3%

All dimensions and technical data are approximate only and may be changed without further notice.





